

REV	ZONE	REVISION	DATE	ECN	NAME	CHKD
B-1	ALL	RELEASE TO PRODUCTION	5/8/12	22725	AEK	DMS
C-1	ALL	ADDED SIGHT GAUGE	9/19/12	PXEC0019	AEK	DMS
D-1	2 CS	MOVED VAC SWITCH MANIFOLD TO CORRECT LOCATION	12/28/12	22723	AEK	DMS
E-1	ALL	MADE HIGH TEMP STANDARD ON BASIC CONTROLS	7/25/14	PXEC0048	AEK	GES
F-1	ALL	CHANGED OUTLET MANIFOLD TO 2"	1/2/15	PXEC0096	AEK	GES
G-1	1 ALL	UPDATED TO PUMP WITH NEMA RATED MOTOR	7/28/16	PXEC0149	AEK	GES

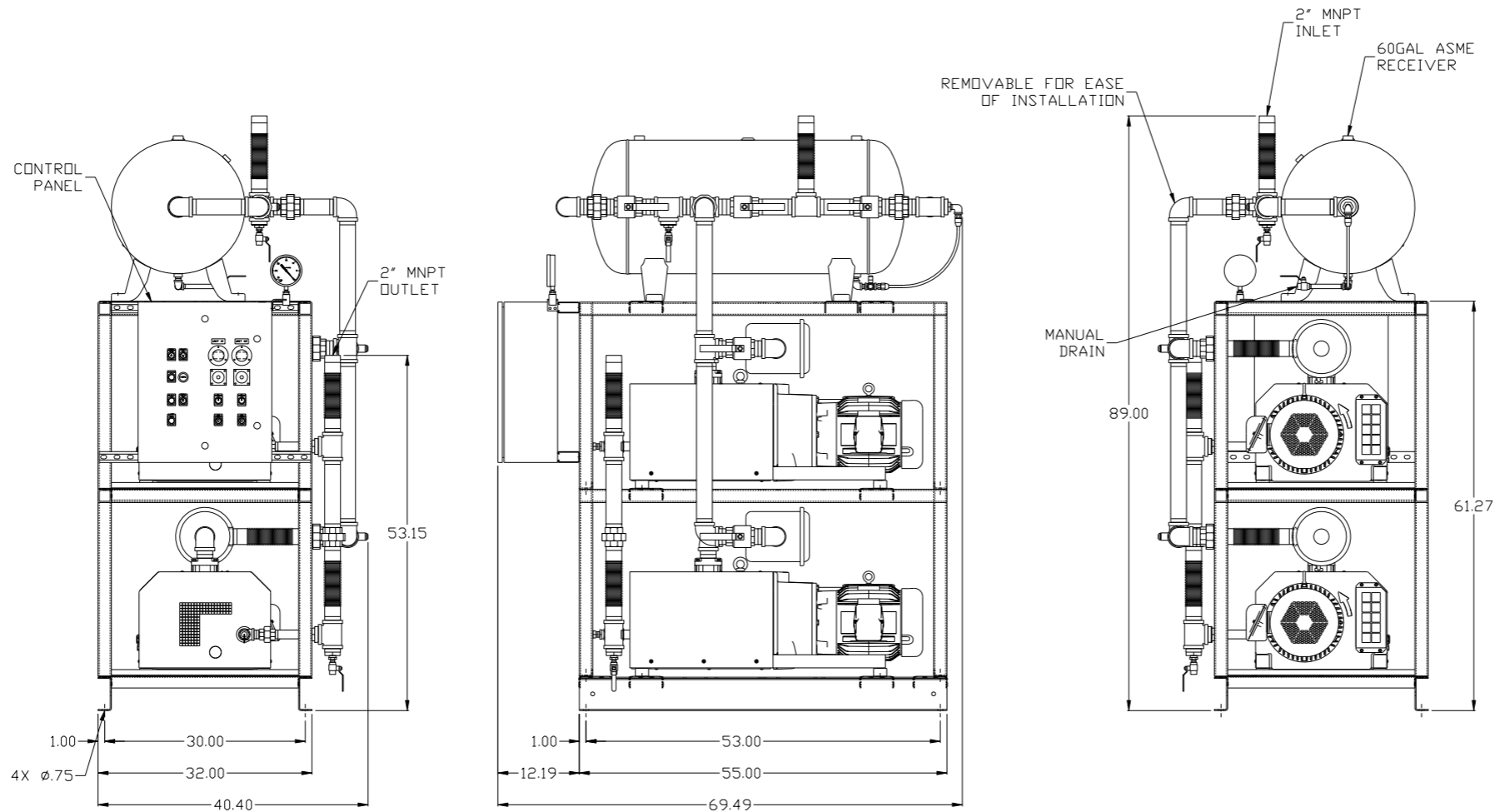
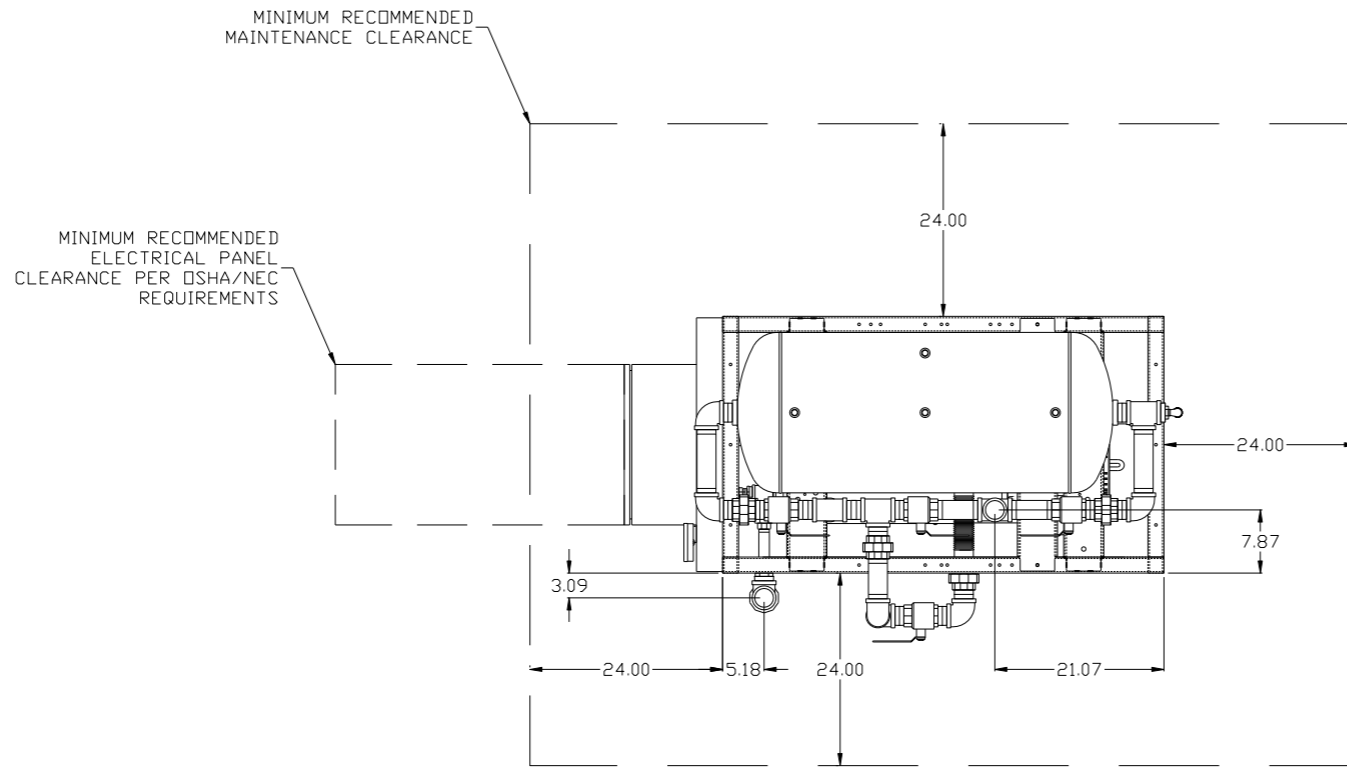

NOTE: SYSTEM DESIGNED IN COMPLIANCE WITH U.S. NFPA '99, LATEST EDITION.

SYMBOL LEGEND ⊖ = MINUS DRAFT ⊕ = PLUS DRAFT ∅ = ADDITIONAL CONTROL REQ'D HRC = BRINELL HARDNESS		Drawings to conform to the current revision of the following ANSI standards: Y14.3 Multi and sectional view dsgs. Y14.5M Dimensioning and tolerancing	
TOLERANCES NOT SPECIFIED .XX ± .XXX ± \angle DEG ±		DO NOT SCALE DRAWING FOR DIMENSIONS Sheet 1 of 2 SCALE 1:12	
CONFIDENTIAL DISCLOSURE This drawing is the property of POWEREX, INC. of the SCOTT FETZER COMPANY and subject to return on demand. Its contents are confidential and must not be copied or submitted to outside parties for use or examination.			
DRAWN BY AEK		CHECKED BY DMS	
5/8/12		APPROVED BY AEK RJR 5/8/12 5/8/12	
MATERIAL N/A			
PART NAME 7.5HP CLAW VAC 60GAL DUPLEX		 150 PRODUCTION DRIVE, HARRISON, OHIO 45030 Ph: 888-769-7979 FAX: (513) 367-3125	
DWG NO CVPDT0752B		SIZE D	

REV	ZONE	REVISION	DATE	ECN	NAME	CHKD
B-1	ALL	RELEASE TO PRODUCTION	5/8/12	22725	AEK	DMS
C-1	ALL	ADDED SIGHT GAUGE	9/19/12	PXEC0019	AEK	DMS
D-1	2 CS	MOVED VAC SWITCH MANIFOLD TO CORRECT LOCATION	12/28/12	22723	AEK	DMS
E-1	ALL	MADE HIGH TEMP STANDARD DN BASIC CONTROLS	7/25/14	PXEC0048	AEK	GES
F-1	ALL	CHANGED OUTLET MANIFOLD TO 2"	1/2/15	PXEC0096	AEK	GES
G-1	1 ALL	UPDATED TO PUMP WITH NEMA RATED MOTOR	7/28/16	PXEC0149	AEK	GES

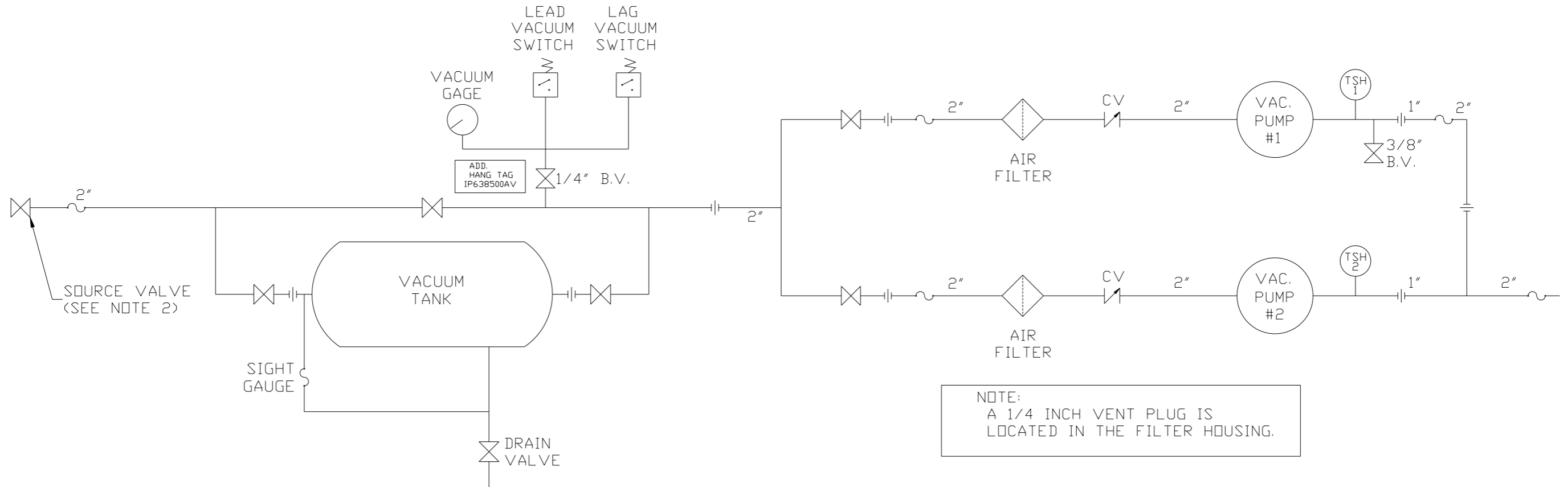

NOTE:
A 1/4 INCH VENT PLUG IS
LOCATED IN THE FILTER HOUSING.

NOTES:
1) TSH - TEMPERATURE SWITCH HIGH
2) PER NFPA THE SYSTEM WILL REQUIRE A SOURCE VALVE (SUPPLIED BY OTHERS).

LEGEND	
TSH	TEMP. SWITCH
	VACUUM SWITCH
	AIR FILTER
	BALL VALVE
	CHECK VALVE
	FLEX LINE
	UNION

SYMBOL LEGEND ⊖ = MINUS DRAFT ⊕ = PLUS DRAFT TOLERANCES NOT SPECIFIED .XX ± .XXX ± \angle (DEG) ±		= ADDITIONAL CONTROL REQ'D = BRINELL HARDNESS	Drawings to conform to the current revision of the following ANSI standards: Y14.3 Multi and sectional view dgs. Y14.5M Dimensioning and tolerancing
AUTOCAD REL2008 LT INCH		DO NOT SCALE DRAWING FOR DIMENSIONS Sheet 2 of 2 SCALE 1:12	
CONFIDENTIAL DISCLOSURE This drawing is the property of POWEREX, INC. of the SCOTT FETZER COMPANY and subject to return on demand. Its contents are confidential and must not be copied or submitted to outside parties for use or examination.		DRAWN BY AEK	CHECKED BY DMS
MATERIAL N/A		APPROVED BY AEK	MFG/MKTG RJR
PART NAME DUPLEX CLAW VACUUM FLOW SCHEMATIC		DATE 5/8/12	DATE 5/8/12
DWG NO CVPDT0752B		SIZE D	



REV	ZONE	REVISION	DATE	ECN	NAME	CHKD
B-1	ALL	RELEASE TO PRODUCTION	5/8/12	22725	AEK	DMS
C-1	ALL	ADDED SIGHT GAUGE	9/19/12	PXEC0019	AEK	DMS
D-1	2 CS	MOVED VAC SWITCH MANIFOLD TO CORRECT LOCATION	12/28/12	22723	AEK	DMS
E-1	ALL	MADE HIGH TEMP STANDARD ON BASIC CONTROLS	7/25/14	PXEC0048	AEK	GES
F-1	ALL	CHANGED OUTLET MANIFOLD TO 2"	1/2/15	PXEC0096	AEK	GES
G-1	1 ALL	UPDATED TO PUMP WITH NEMA RATED MOTOR	7/28/16	PXEC0149	AEK	GES

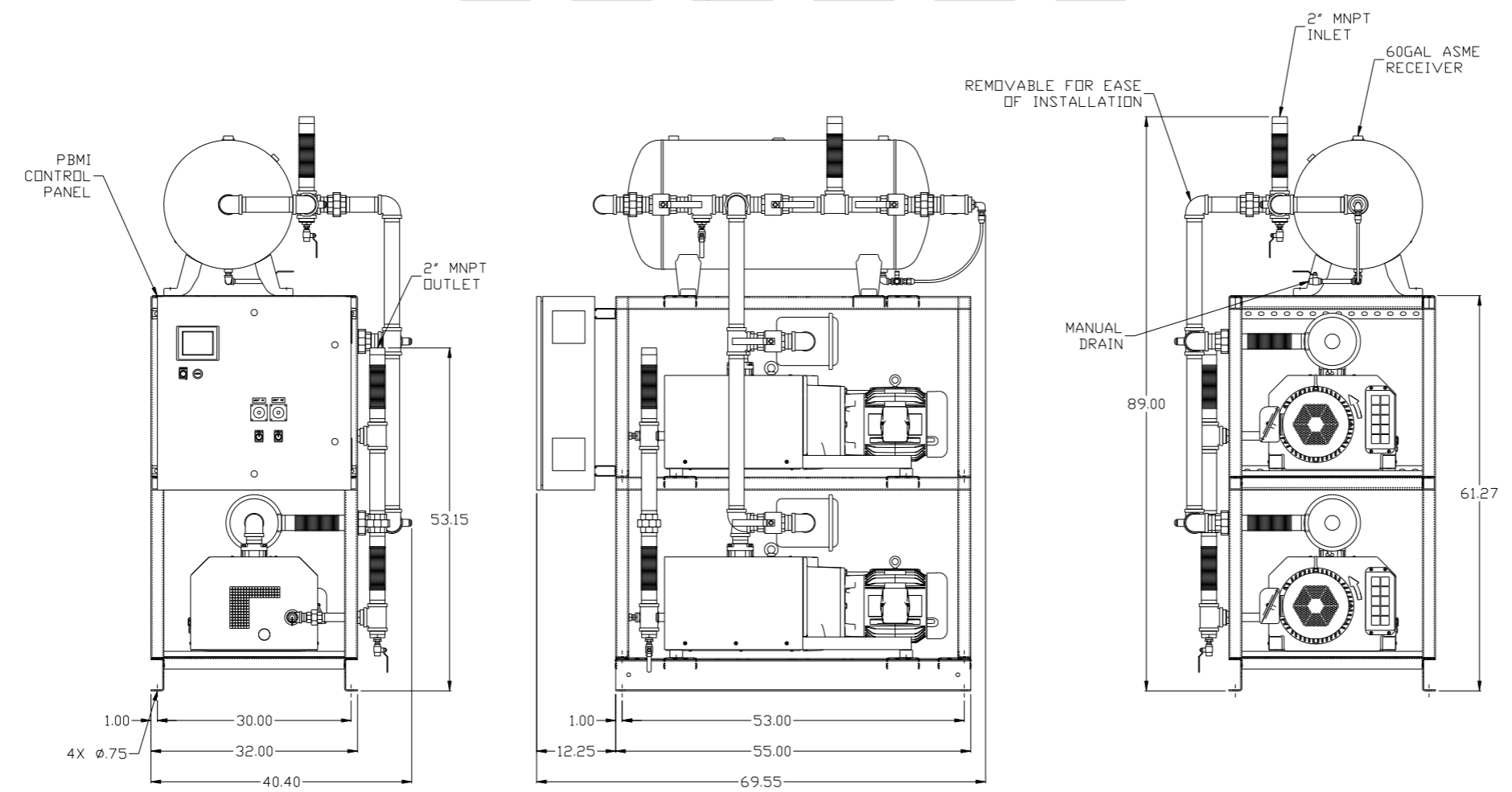
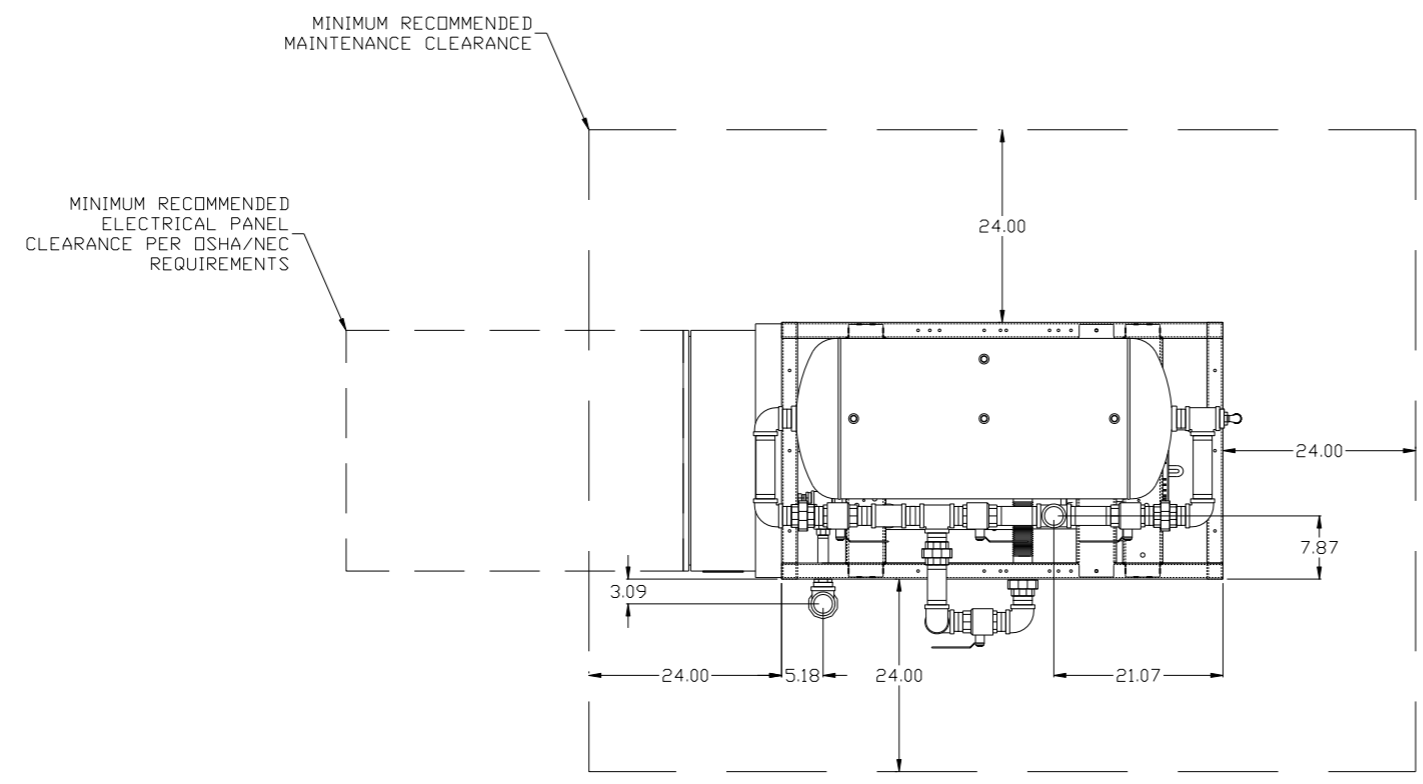

NOTE: SYSTEM DESIGNED IN COMPLIANCE WITH U.S. NFPA '99, LATEST EDITION.

SYMBOL LEGEND ⊖ = MINUS DRAFT ⊕ = PLUS DRAFT .XX ± .XXX ± << DEG >> ±		= ADDITIONAL CONTROL REQ'D = BRINELL HARDNESS		Drawings to conform to the current revision of the following ANSI standards: Y14.3 Multi and sectional view dsgs. Y14.5M Dimensioning and tolerancing	
TOLERANCES NOT SPECIFIED AUTOCAD REL2008 LT INCH		DO NOT SCALE DRAWING FOR DIMENSIONS Sheet 1 of 2 SCALE 1:12			
CONFIDENTIAL DISCLOSURE This drawing is the property of POWEREX, INC. of the SCOTT FETZER COMPANY and subject to return on demand. Its contents are confidential and must not be copied or submitted to outside parties for use or examination.		DRAWN BY AEK	CHECKED BY DMS	APPROVED BY AEK	MFG/MKTG RJR
MATERIAL N/A		5/8/12	5/8/12	5/8/12	5/8/12
PART NAME 7.5HP CLAW VAC 60GAL DUPLEX		 150 PRODUCTION DRIVE, HARRISON, OHIO 45030 Ph: 888-769-7979 FAX: (513) 367-3125		DWG NO CVPDT0752B	SIZE D

REV	ZONE	REVISION	DATE	ECN	NAME	CHKD
B-1	ALL	RELEASE TO PRODUCTION	5/8/12	22725	AEK	DMS
C-1	ALL	ADDED SIGHT GAUGE	9/19/12	PXEC0019	AEK	DMS
D-1	2 CS	MOVED VAC SWITCH MANIFOLD TO CORRECT LOCATION	12/28/12	22723	AEK	DMS
E-1	ALL	MADE HIGH TEMP STANDARD DN BASIC CONTROLS	7/25/14	PXEC0048	AEK	GES
F-1	ALL	CHANGED OUTLET MANIFOLD TO 2"	1/2/15	PXEC0096	AEK	GES
G-1	1 ALL	UPDATED TO PUMP WITH NEMA RATED MOTOR	7/28/16	PXEC0149	AEK	GES

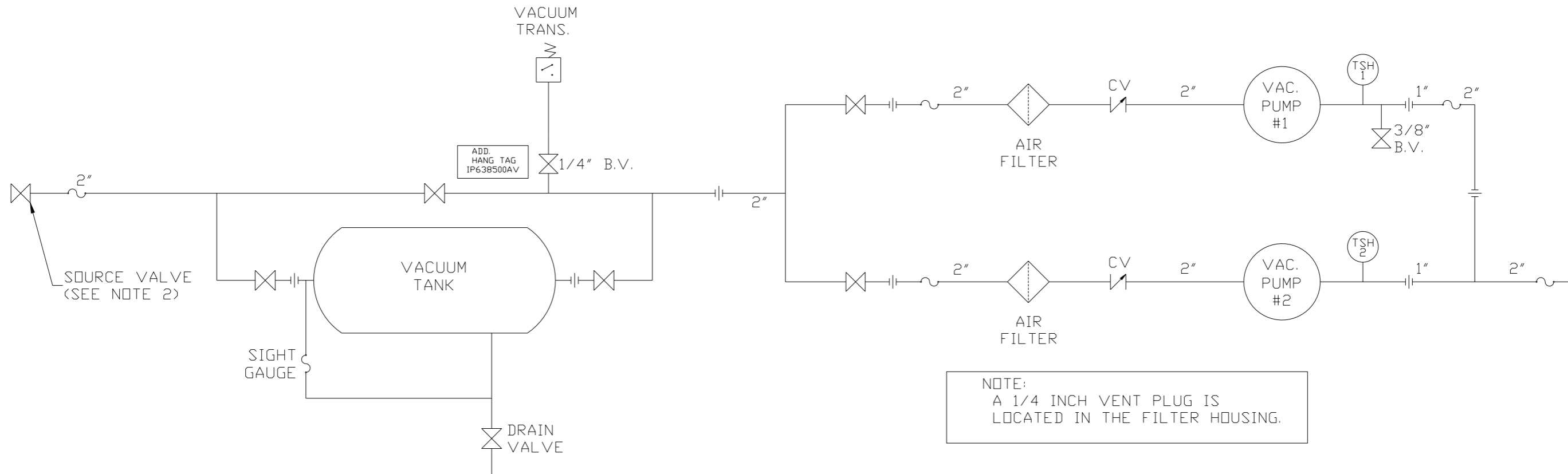

NOTE:
A 1/4 INCH VENT PLUG IS
LOCATED IN THE FILTER HOUSING.

NOTES:
1) TSH - TEMPERATURE SWITCH HIGH
2) PER NFPA THE SYSTEM WILL REQUIRE A SOURCE VALVE (SUPPLIED BY OTHERS).

LEGEND	
TEMP. SWITCH	VACUUM SWITCH
AIR FILTER	CHECK VALVE
BALL VALVE	FLEX LINE
	UNION

SYMBOL LEGEND		= ADDITIONAL CONTROL REQ'D	Drawings to conform to the current revision of the following ANSI standards		
= MINUS DRAFT	= PLUS DRAFT	= BRINELL HARDNESS	Y14.3 Multi and sectional view dgs. Y14.5M Dimensioning and tolerancing		
TOLERANCES NOT SPECIFIED	AUTOCAD REL2008 LT	DO NOT SCALE DRAWING FOR DIMENSIONS			
.XX ±	INCH	Sheet 2 of 2	SCALE 1:12		
CONFIDENTIAL DISCLOSURE This drawing is the property of POWEREX, INC. of the SCOTT FETZER COMPANY and subject to return on demand. Its contents are confidential and must not be copied or submitted to outside parties for use or examination.		DRAWN BY AEK	CHECKED BY DMS	APPROVED BY ENGINEERING AEK	MFG/MKTG RJR
MATERIAL	N/A	5/8/12	5/8/12	5/8/12	5/8/12
PART NAME	DUPLEX CLAW VACUUM FLOW SCHEMATIC			SIZE D	
DWG NO	CVPDT0752B	150 PRODUCTION DRIVE, HARRISON, OHIO 45030 Ph: 888-769-7979 FAX: (513) 367-3125		CVPDT0752B.dwg	