

REV	ZONE	REVISION	DATE	ECN	NAME	CHKD
B-1	ALL	RELEASE TO PRODUCTION	9/23/10	22470	GES	DMS
B-2	1 ALL 2 C-2	STAGGERED DRYERS PER PRODUCTION ADDED REG TO DP LINE	10/27/10	22470	AEK	GES
B-3	2C-7	ADDED UNLOADER LINES TO PUMPS	11/4/10	22470	AEK	GES
B-4	2 C2 1 ALL	REMOVED REGULATOR FROM DP MONITOR LINE REPLACED PUMP ISO SPRINGS W/ ISO PAD	11/29/10	22470	AEK	GES
B-5	2 A6	ADDED DRAIN OIL SEPARATOR NOTE	12/3/10	22470	AEK	GES
B-6	2 D4	CORRECTED GAUGE CALLOUT	2/15/11	22470	AEK	GES
C-1	ALL	ADDED FINAL FILTER	3/11/11	22573	AEK	GES
D-1	1 ALL	MOVED CONTROL PANEL TO ATC SKID	4/21/11	22594	AEK	GES
E-1	2, C6	CHANGED CV POSITION, ADDED BLEED VALVE	5/12/11	22546	GES	DMS
F-1	2 ALL 2 D5	ADDED SEPARATOR E-DRAINS ADDED FLEX LINES ADDED SNUBBER VALVE	3/12/13	PXEC0030	AEK	GES
G-1	2 D5	REMOVED SNUBBER VALVE	5/2/17	PXEC0187	MJD	KMB
H-1	1 ALL	UPDATED TO NAND DRYERS	8/10/17	PXEC0174	AEK	GES

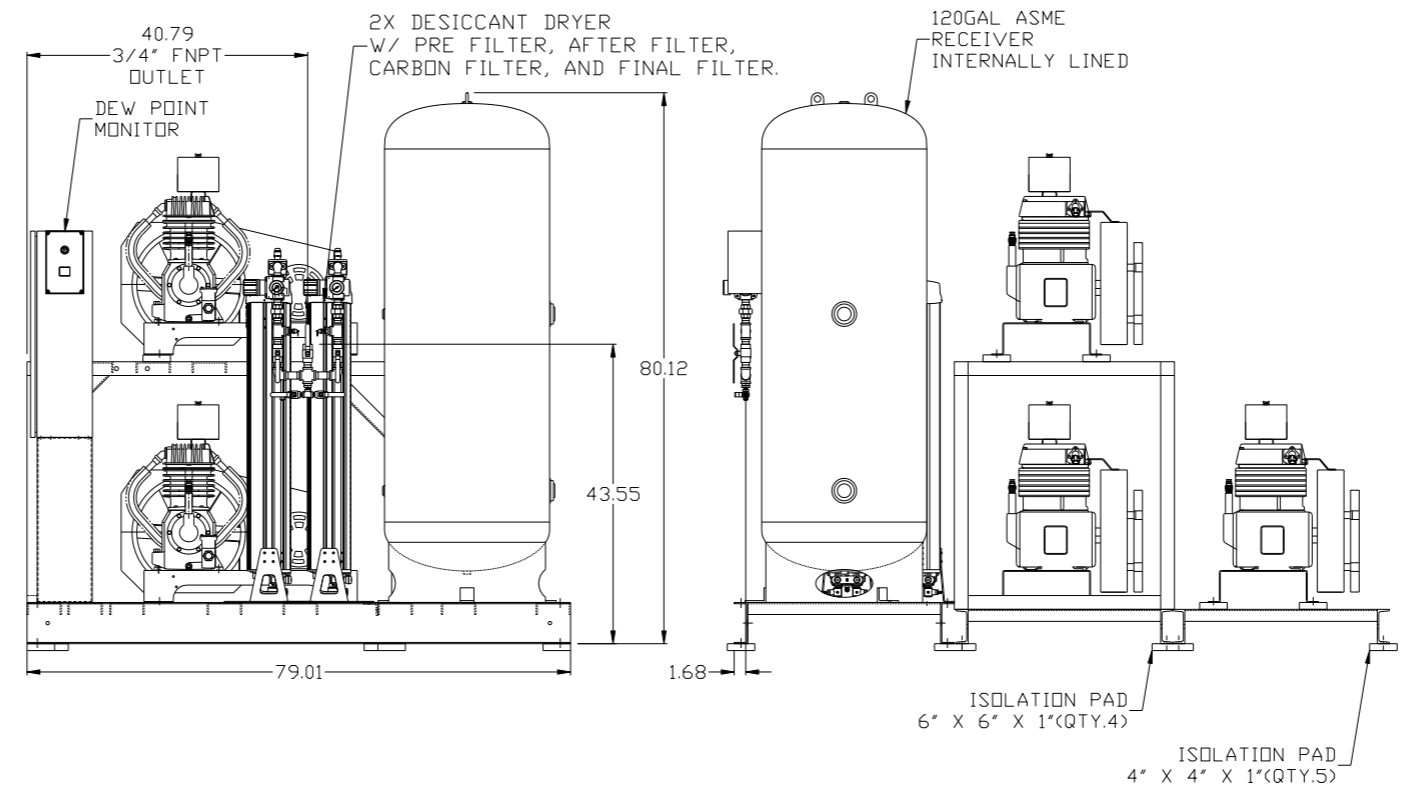
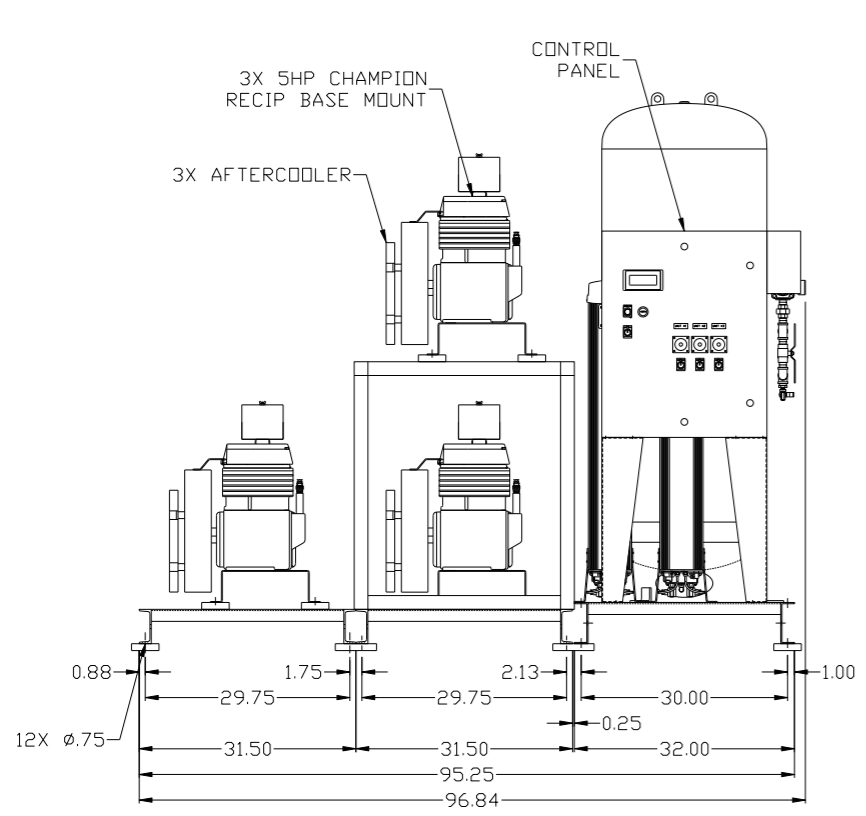
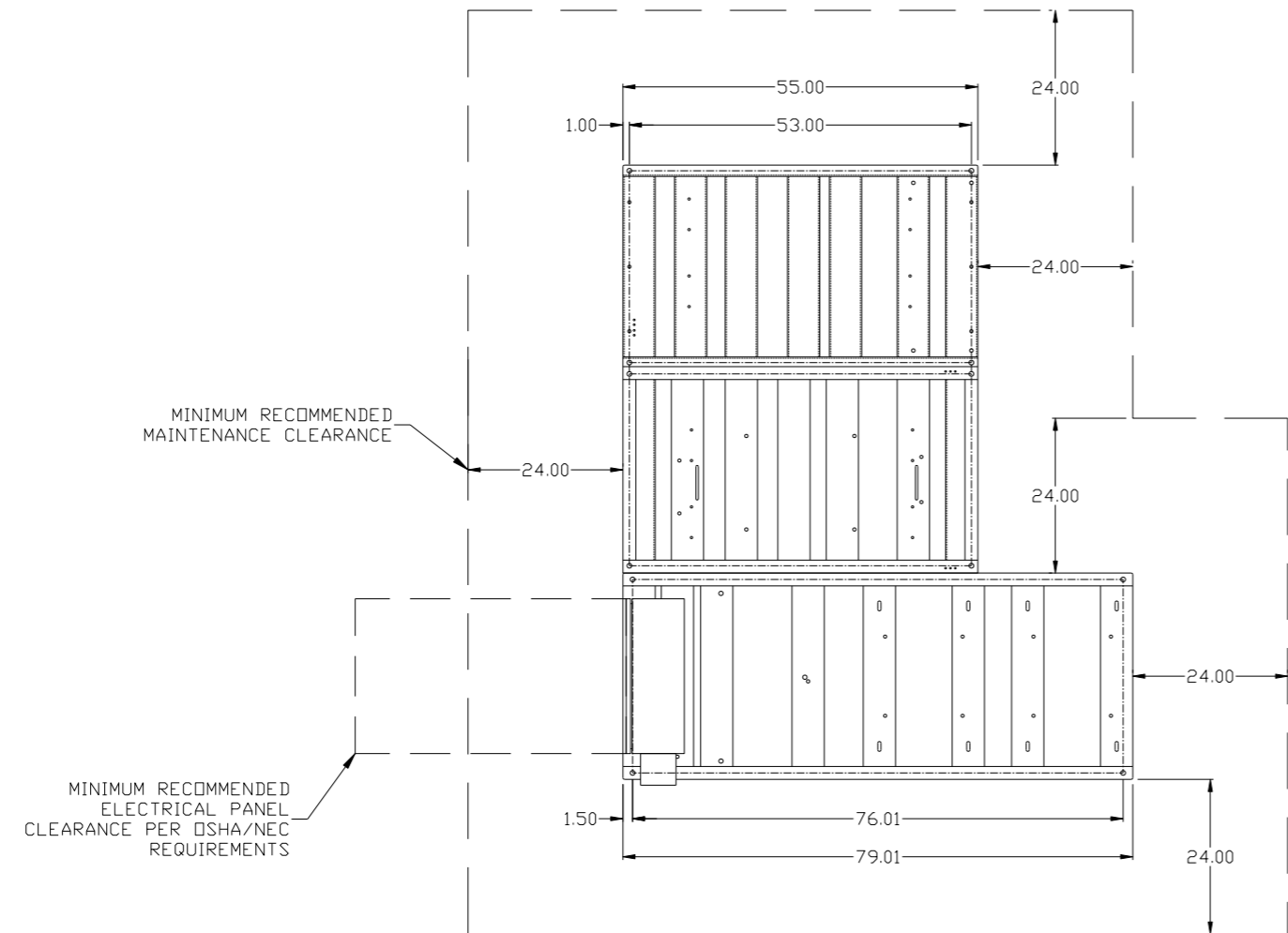

NOTE: SYSTEM DESIGNED IN COMPLIANCE WITH U.S. NFPA '99, LATEST EDITION.

SYMBOL LEGEND		⊖ = MINUS DRAFT	⊕ = PLUS DRAFT	⊕ = ADDITIONAL CONTROL REQ'D	⊕ = BRINELL HARDNESS	Drawings to conform to the current revision of the following ANSI standards: Y14.3 Multi and sectional view dgs. Y14.5M Dimensioning and tolerancing
TOLERANCES NOT SPECIFIED	AUTOCAD REL2008 LT	DO NOT SCALE DRAWING FOR DIMENSIONS		Sheet 1 of 2		
.XX ±	INCH	SCALE		1:14		
.XXX ±		DRAWN BY		APPROVED BY		
<< DEG >> ±		GES		DMS		
CONFIDENTIAL DISCLOSURE This drawing is the property of POWEREX, INC. of the SCOTT FELTZER COMPANY and subject to return on demand. Its contents are confidential and must not be copied or submitted to outside parties for use or examination.		9/23/10		9/23/10		9/23/10
MATERIAL		N/A				
PART NAME		SHP INSTRUMENT AIR TRIPLEX				
120GAL DESICCANT		DVG NO				
		IPT0504X5		SIZE		
				D		

REV	ZONE	REVISION	DATE	ECN	NAME	CHKD
B-1	ALL	RELEASE TO PRODUCTION	9/23/10	22470	GES	DMS
B-2	1 ALL 2 C-2	STAGGERED DRYERS PER PRODUCTION ADDED REG TO DP LINE	10/27/10	22470	AEK	GES
B-3	2C-7	ADDED UNLOADER LINES TO PUMPS	11/4/10	22470	AEK	GES
B-4	2 C2 1 ALL	REMOVED REGULATOR FROM DP MONITOR LINE REPLACED PUMP ISO SPRINGS W/ ISO PAD	11/29/10	22470	AEK	GES
B-5	2 A6	ADDED DRAIN OIL SEPARATOR NOTE	12/3/10	22470	AEK	GES
B-6	2 D4	CORRECTED GAUGE CALLOUT	2/15/11	22470	AEK	GES
C-1	ALL	ADDED FINAL FILTER	3/11/11	22573	AEK	GES
D-1	1 ALL	MOVED CONTROL PANEL TO ATC SKID	4/21/11	22594	AEK	GES
E-1	2, C6	CHANGED CV POSITION, ADDED BLEED VALVE	5/12/11	22546	GES	DMS
F-1	2 ALL 2 D5	ADDED SEPARATOR E-DRAINS ADDED FLEX LINES ADDED SNUBBER VALVE	3/12/13	PXEC0030	AEK	GES
G-1	2 D5	REMOVED SNUBBER VALVE	5/2/17	PXEC0187	MJD	KMB
H-1	1 ALL	UPDATED TO NAMD DRYERS	8/10/17	PXEC0174	AEK	GES

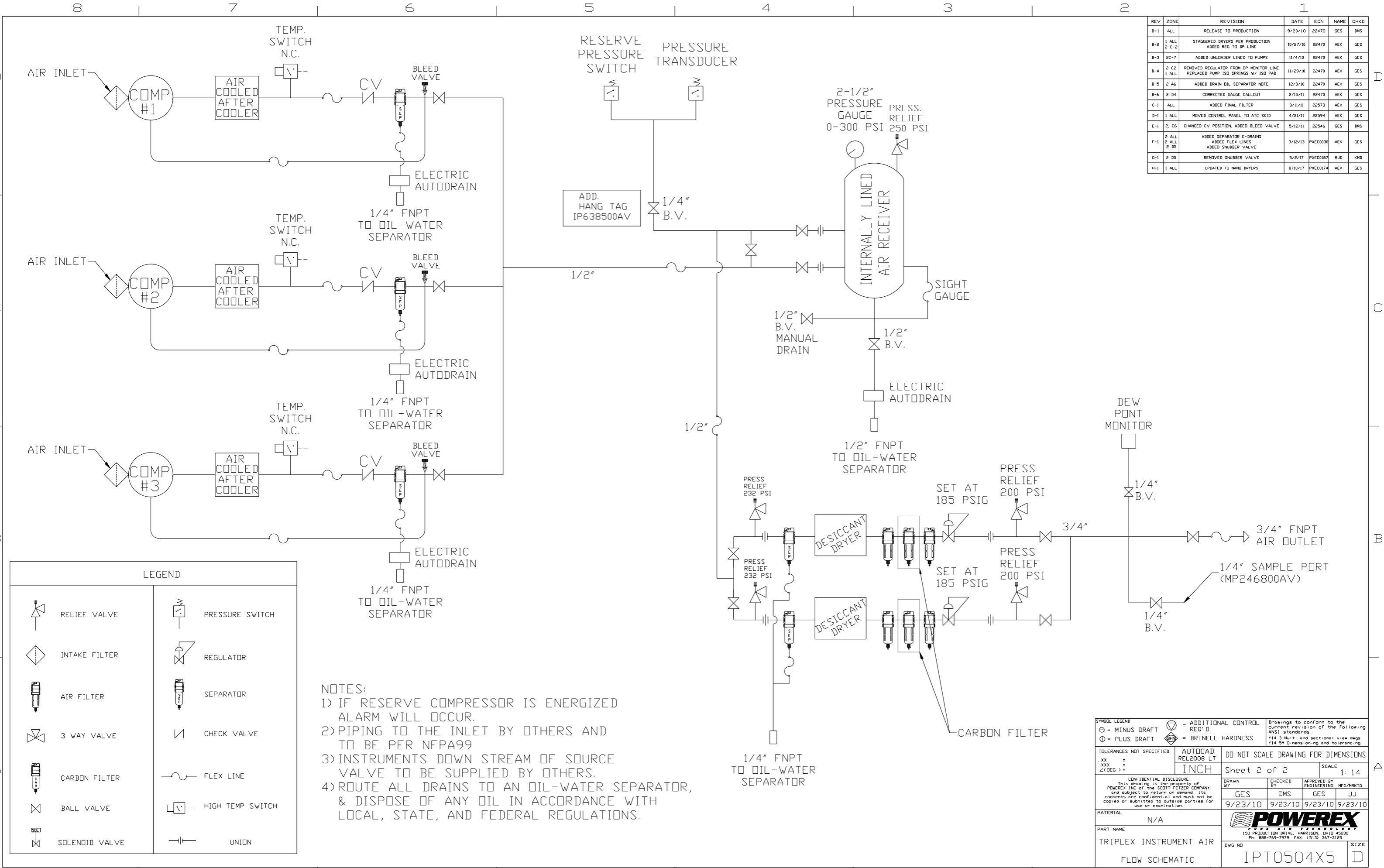

NOTES:
 1) IF RESERVE COMPRESSOR IS ENERGIZED ALARM WILL OCCUR.
 2) PIPING TO THE INLET BY OTHERS AND TO BE PER NFPA99
 3) INSTRUMENTS DOWN STREAM OF SOURCE VALVE TO BE SUPPLIED BY OTHERS.
 4) ROUTE ALL DRAINS TO AN OIL-WATER SEPARATOR, & DISPOSE OF ANY OIL IN ACCORDANCE WITH LOCAL, STATE, AND FEDERAL REGULATIONS.

SYMBOL LEGEND ⊖ = MINUS DRAFT ⊕ = PLUS DRAFT TOLERANCES NOT SPECIFIED .XX ± .XXX ± \angle DEG ±		⊕ = ADDITIONAL CONTROL REQ'D ⊕ = BRINELL HARDNESS Drawings to conform to the current revision of the following ANSI standards Y14.3 Multi and sectional view dsgs. Y14.5M Dimensioning and tolerancing	
AUTOCAD REL2008 LT INCH DO NOT SCALE DRAWING FOR DIMENSIONS Sheet 2 of 2 SCALE 1:14		CONFIDENTIAL DISCLOSURE This drawing is the property of POWEREX, INC. of the SCOTT FETZER COMPANY and subject to return on demand. Its contents are confidential and must not be copied or submitted to outside parties for use or examination.	
DRAWN BY GES 9/23/10		CHECKED BY DMS 9/23/10	
APPROVED BY ENGINEERING GES 9/23/10		APPROVED BY MFG/MKTG JJ 9/23/10	
MATERIAL N/A		POWEREX 150 PRODUCTION DRIVE, HARRISON, OHIO 45030 Ph 888-769-7979 FAX (513) 367-3125	
PART NAME TRIPLEX INSTRUMENT AIR FLOW SCHEMATIC		DWG NO IPT0504X5 SIZE D	