

REVISION NOTES		
DESCRIPTION	ECN	PR/NOR
PRODUCTION RELEASE	PXEC0169	N/A

# MST15A4

## MEDICAL OPEN SCROLL 15HP TRIPLEX WITH 120 GALLON TANK PREMIUM PANEL

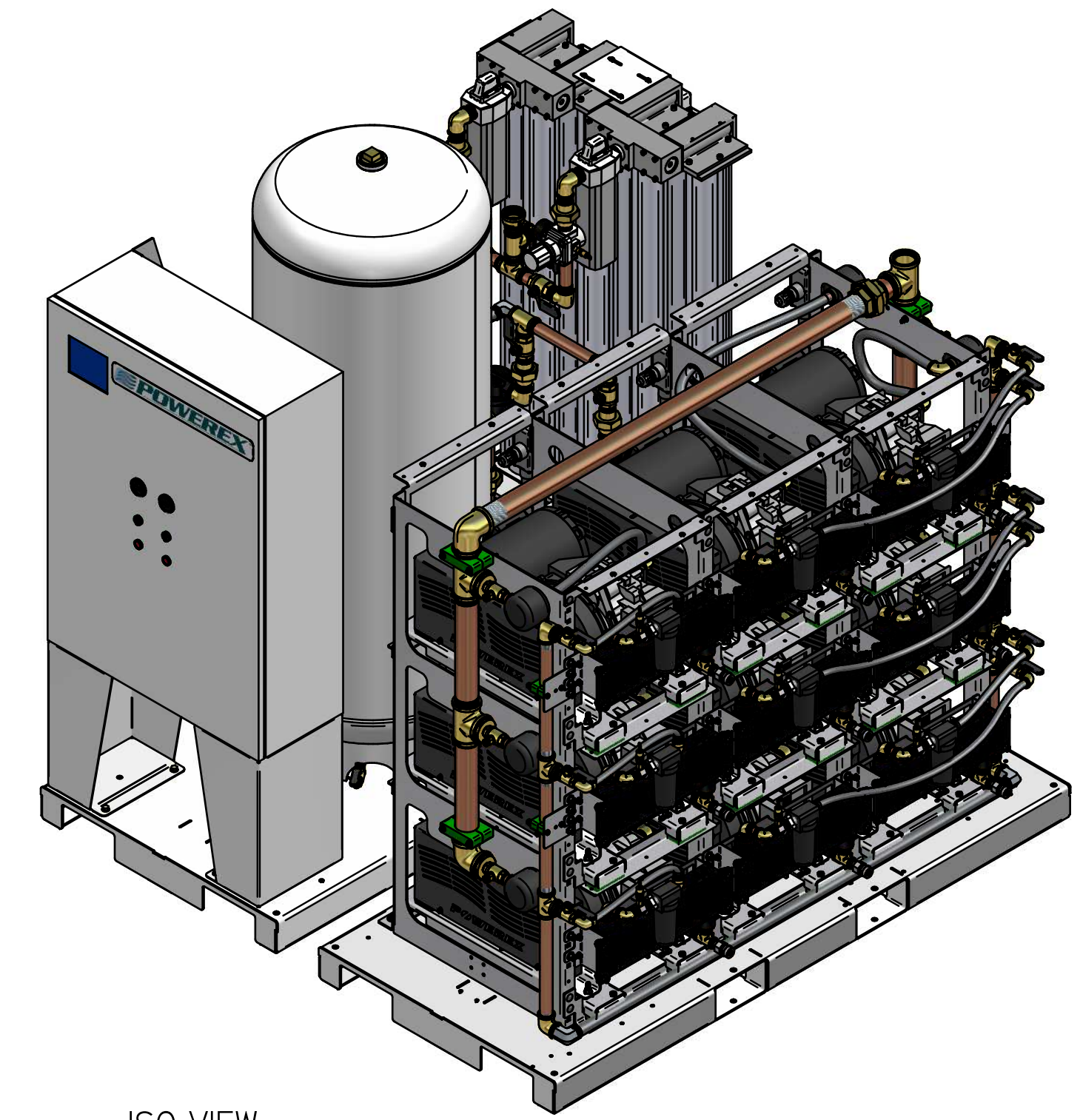
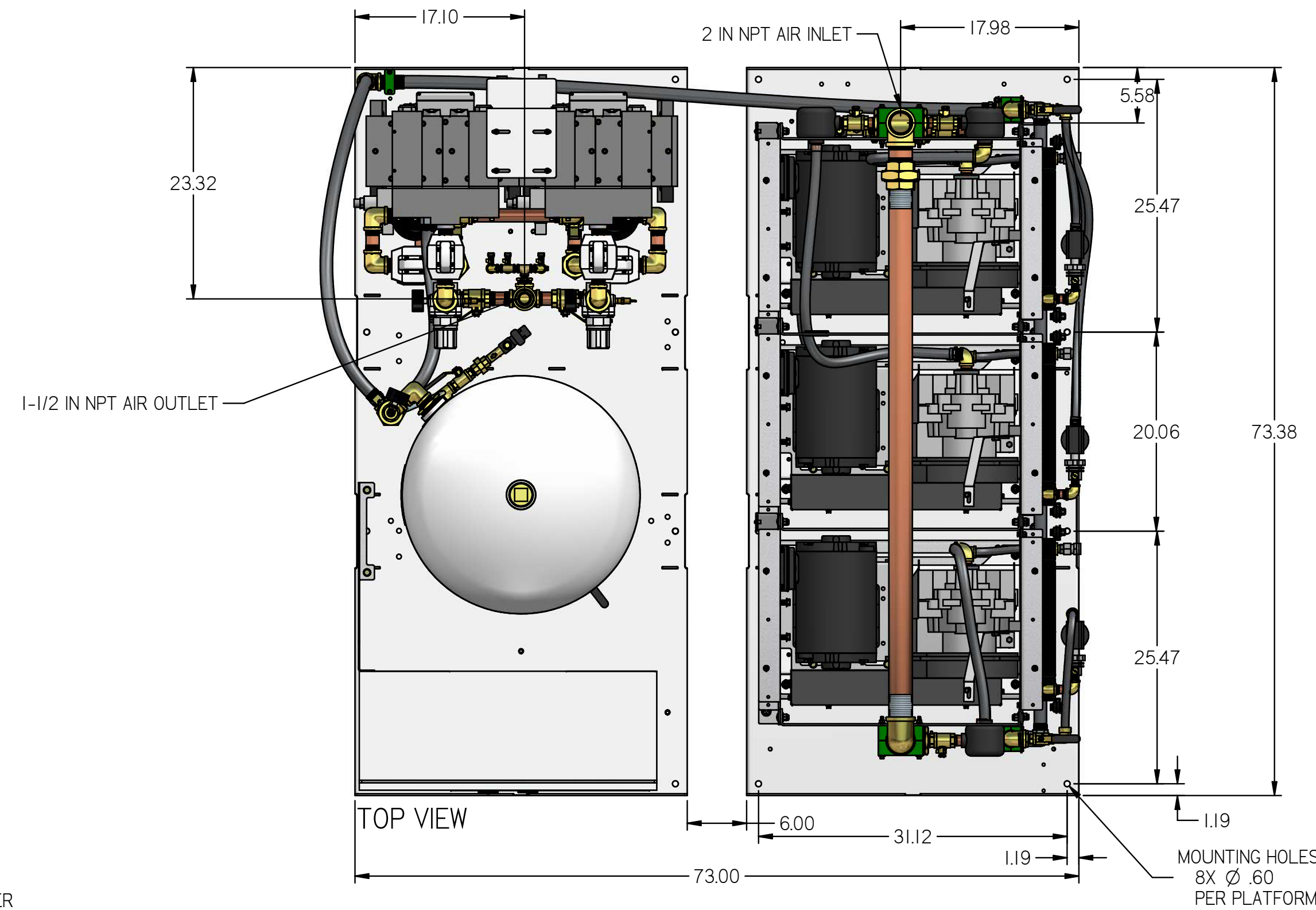

ISO VIEW

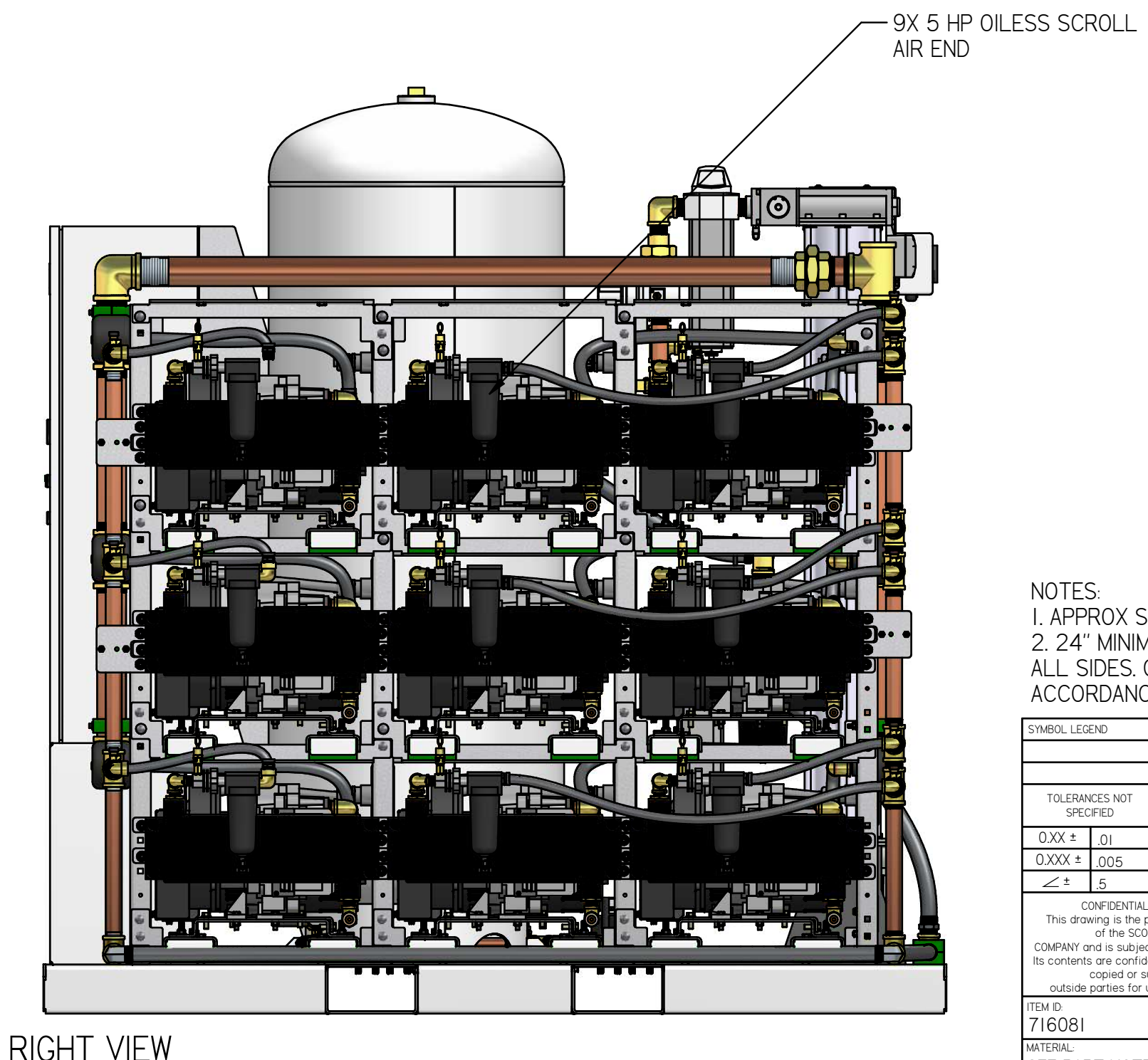
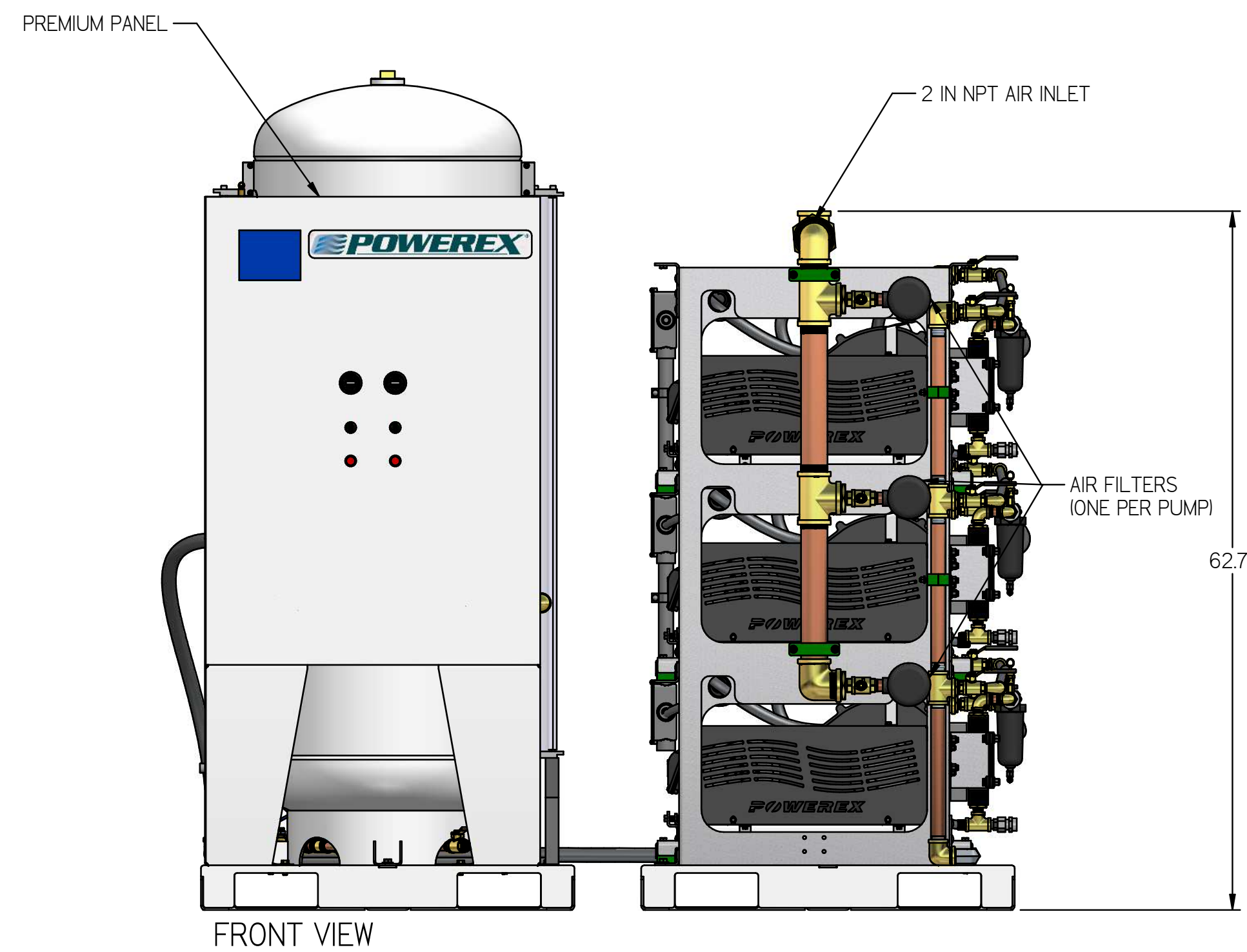
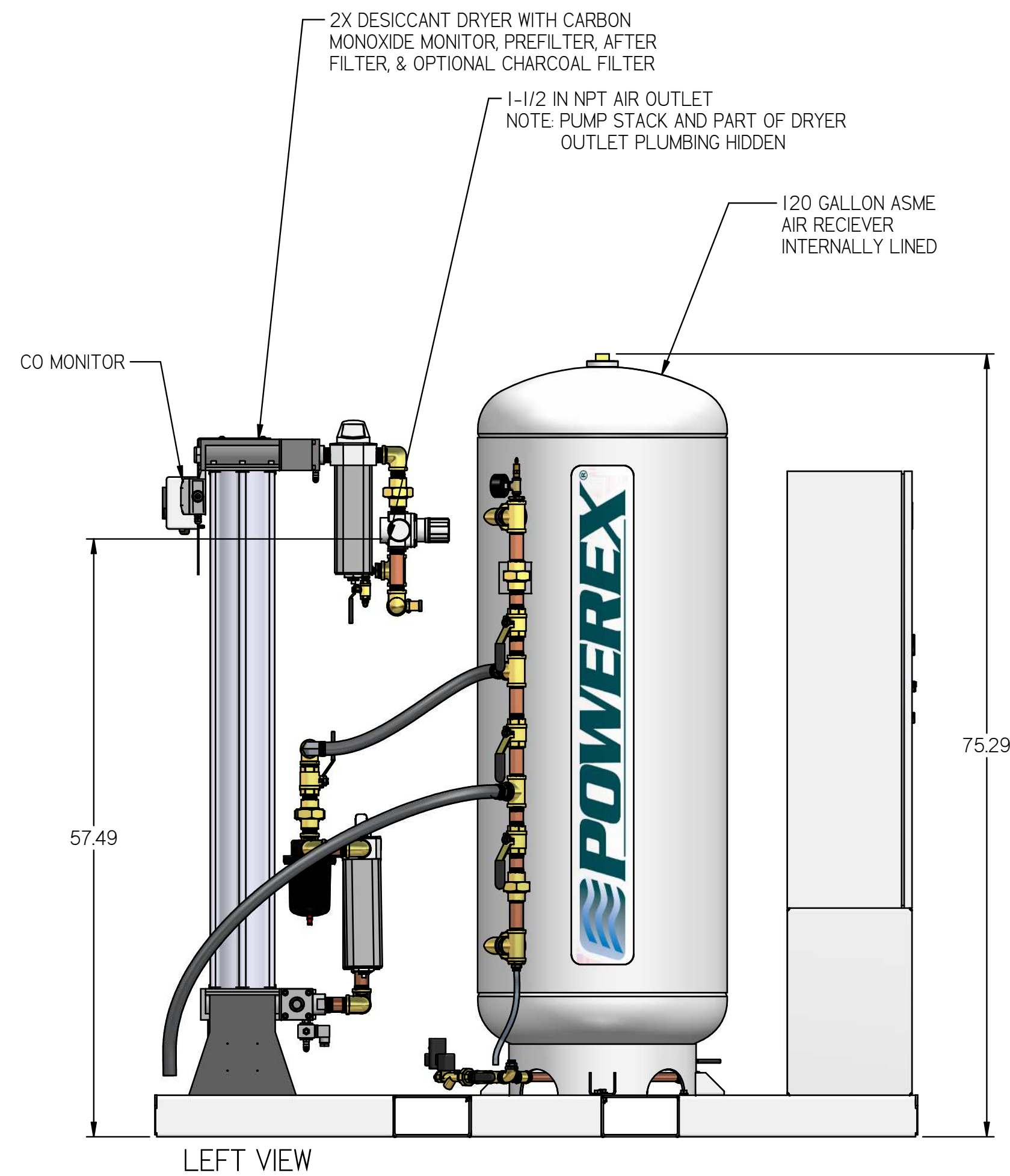

- NOTES:  
 1. APPROX SYSTEM WEIGHT: 3927 LB  
 2. 24" MINIMUM MAINTENANCE CLEARANCE RECOMMENDED  
 ALL SIDES. CLEARANCE FOR CONTROL PANEL SHALL BE IN ACCORDANCE WITH OSHA/NEC REQUIREMENTS

SYMBOL LEGEND		DRAWINGS TO CONFORM TO CURRENT REVISION OF THE FOLLOWING ANSI STANDARDS: Y14.3 MULTI AND SECTIONAL VIEW DWGS Y14.5 DIMENSIONING AND TOLERANCING		
TOLERANCES NOT SPECIFIED	SOLID EDGE DRAWING	DO NOT SCALE DRAWING FOR DIMENSIONS		
0.XXX ± .01	INCH	SHEET 1 OF 5	SCALE	1:1.11
0.XXX ± .005				
CONFIDENTIAL DISCLOSURE: This drawing is the property of POWEREX of the SCOTT FETTER COMPANY and is subject to return on demand. Its contents are confidential and must not be copied or submitted to outside parties for use or examination.		AUTHOR	ORIGINATION DATE	APPROVALS ON FILE IN PLM
PART NO: 716081		ASoulek	11/5/2018	
MATERIAL: SEE PART NOTES				
DESCRIPTION: MEDICAL OPEN SCROLL 15HP TRIPLEX WITH 120 GALLON TANK				
DRAWING NUMBER: MST15A4		REVISION: B	SIZE: D	

REVISION NOTES		
DESCRIPTION	ECN	PR/NOR
PRODUCTION RELEASE	PXEC0169	N/A

# MST15A4

## MEDICAL OPEN SCROLL 15HP TRIPLEX WITH 120 GALLON TANK BASIC PANEL

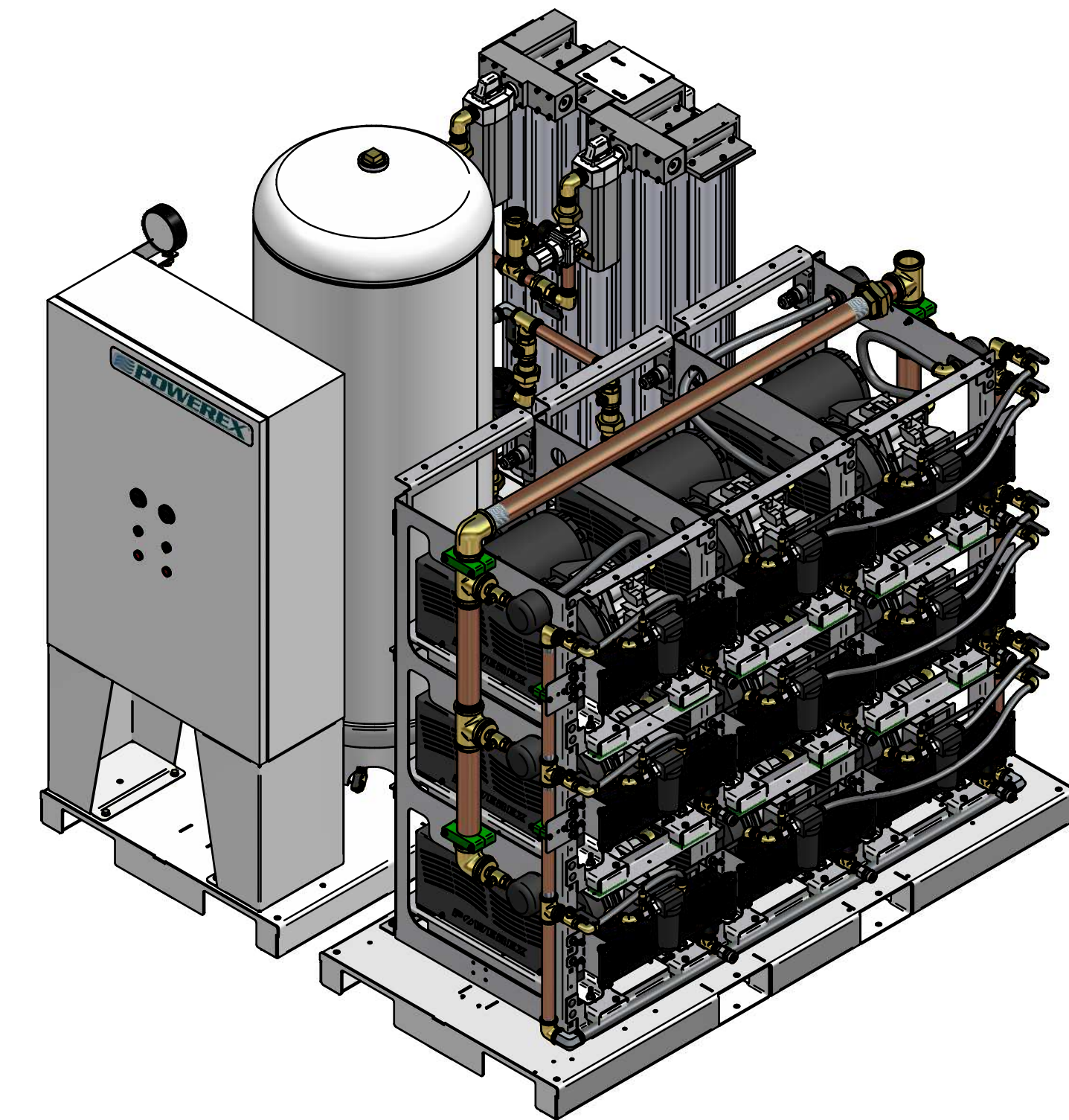
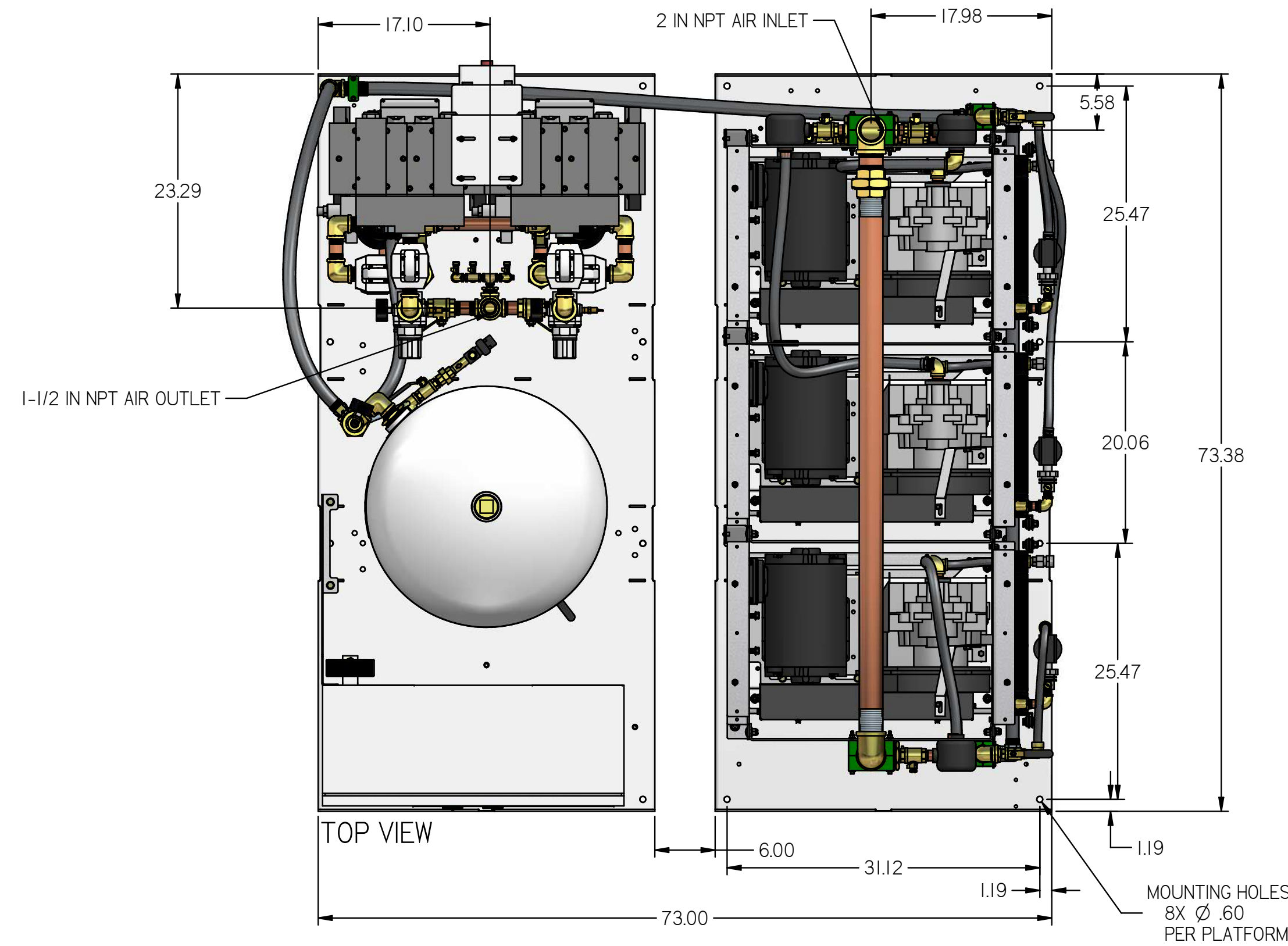

ISO VIEW

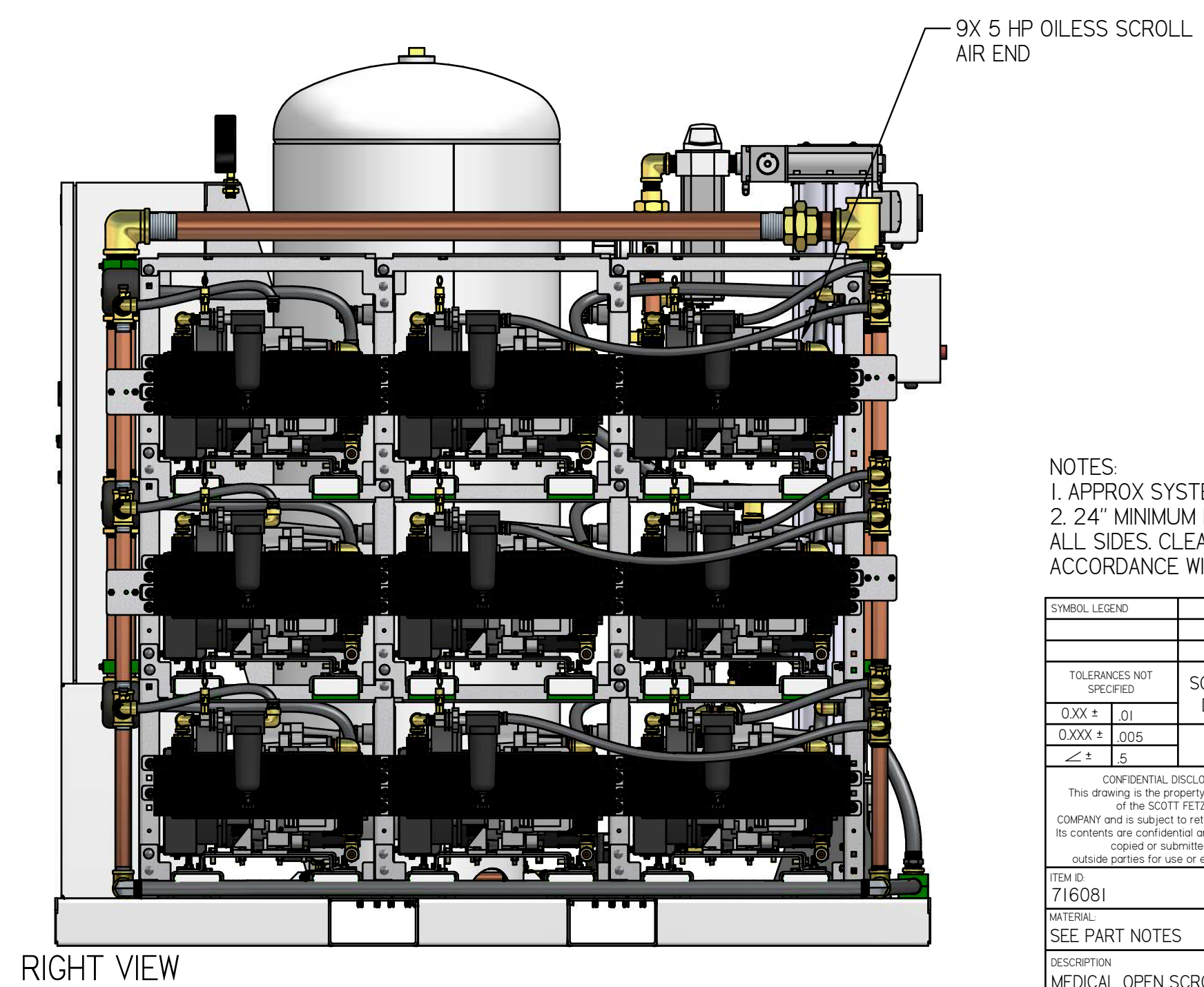
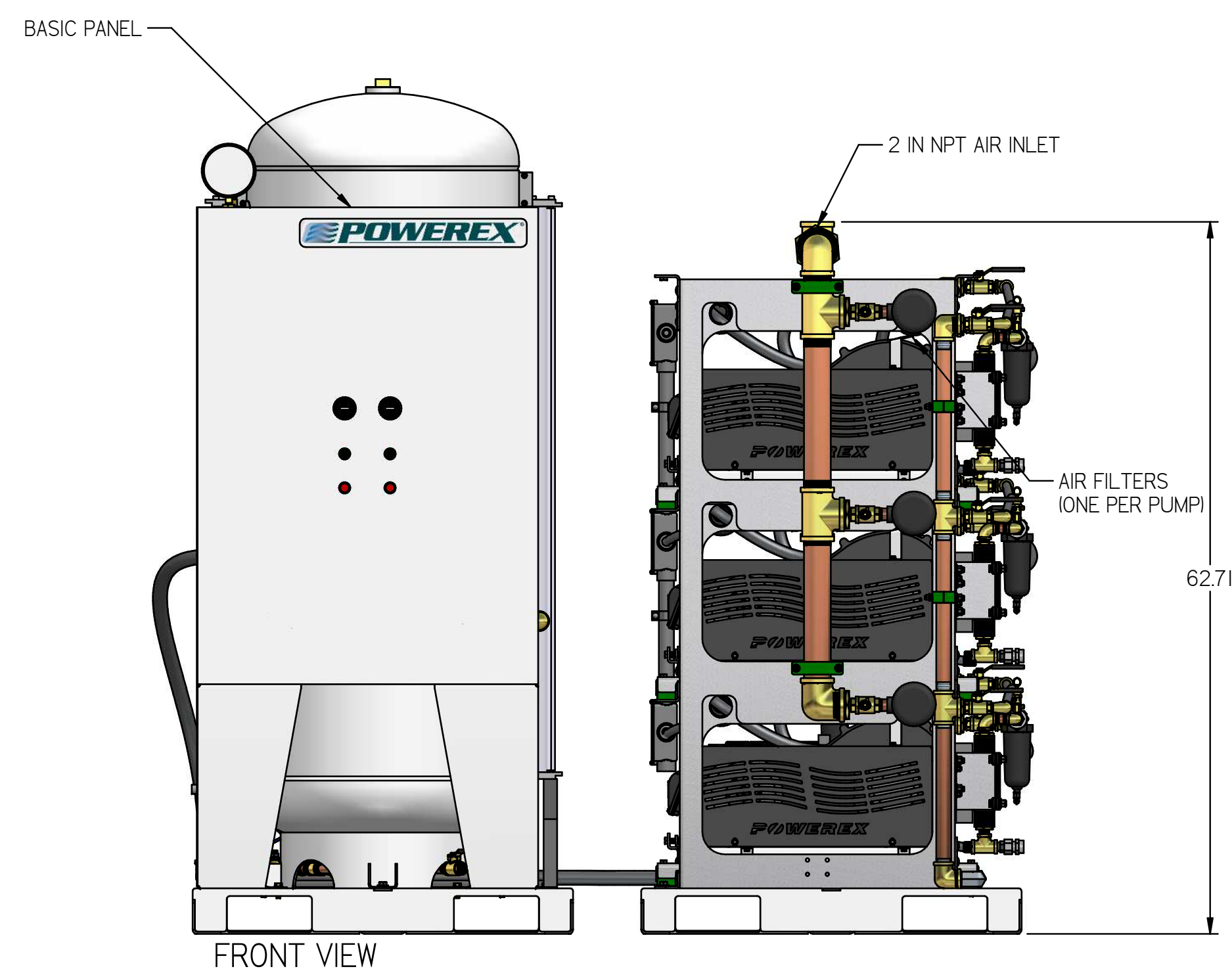
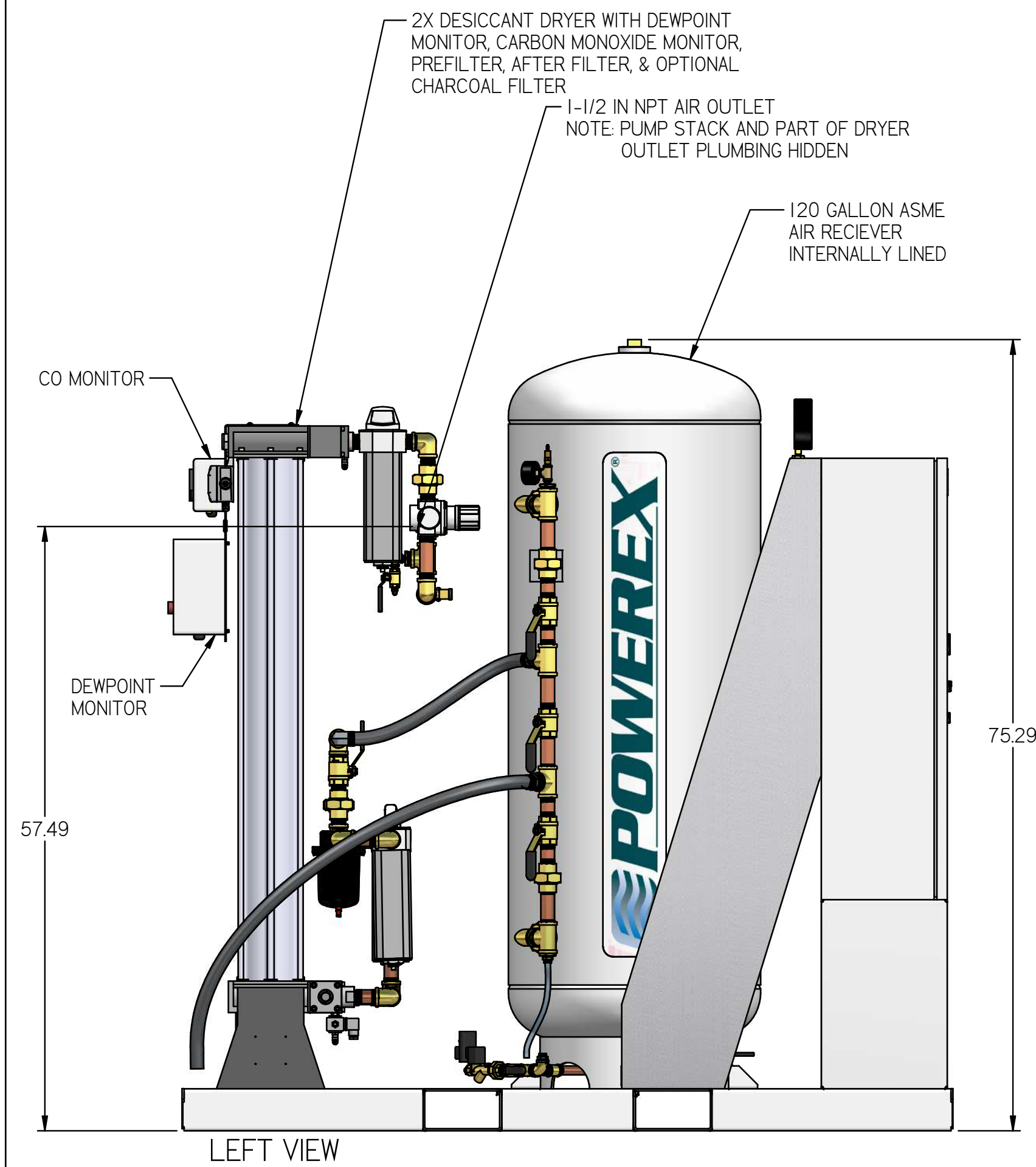

- NOTES:
- APPROX SYSTEM WEIGHT: 3927 LB
  - 24" MINIMUM MAINTENANCE CLEARANCE RECOMMENDED ALL SIDES. CLEARANCE FOR CONTROL PANEL SHALL BE IN ACCORDANCE WITH OSHA/NEC REQUIREMENTS

SYMBOL LEGEND		DRAWINGS TO CONFORM TO CURRENT REVISION OF THE FOLLOWING ANSI STANDARDS:		
TOLERANCES NOT SPECIFIED	SOLID EDGE DRAWING	DO NOT SCALE DRAWING FOR DIMENSIONS		
0.XXX ± .01	IND	SHEET 2 OF 5	SCALE	1:1
0.XXX ± .005				
CONFIDENTIAL DISCLOSURE This drawing is the property of POWEREX of the SCOTT FETTER COMPANY and is subject to return on demand. Its contents are confidential and must not be copied or submitted to outside parties for use or examination.		AUTHOR	ORIGINATION DATE	APPROVALS ON FILE IN PLM
PART NO: 716081		ASoulek	11/5/2018	
MATERIAL: SEE PART NOTES				
DESCRIPTION: MEDICAL OPEN SCROLL 15HP TRIPLEX WITH 120 GALLON TANK				
		DRAWING NUMBER MST15A4	REVISION B	SIZE D

REVISION NOTES		
DESCRIPTION	ECN	PR/NOR
PRODUCTION RELEASE	PXECO169	N/A

# MST15A4

## MEDICAL OPEN SCROLL 15HP TRIPLEX WITH 120 GALLON TANK

SYSTEM FLOW DIAGRAM

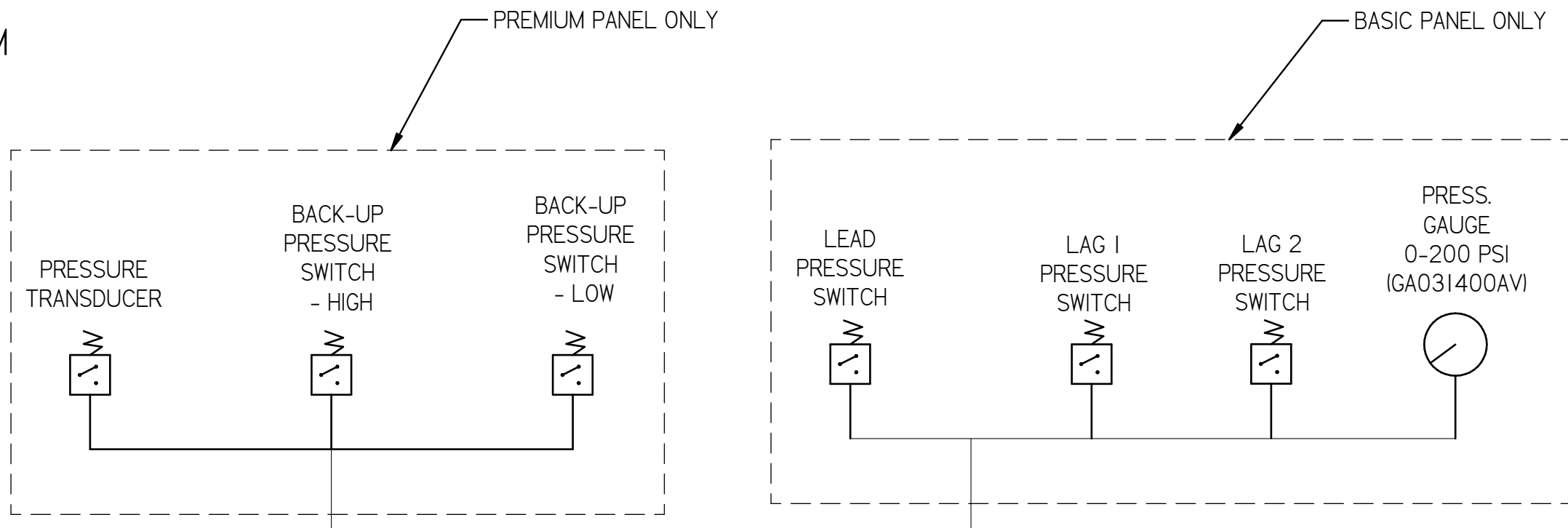
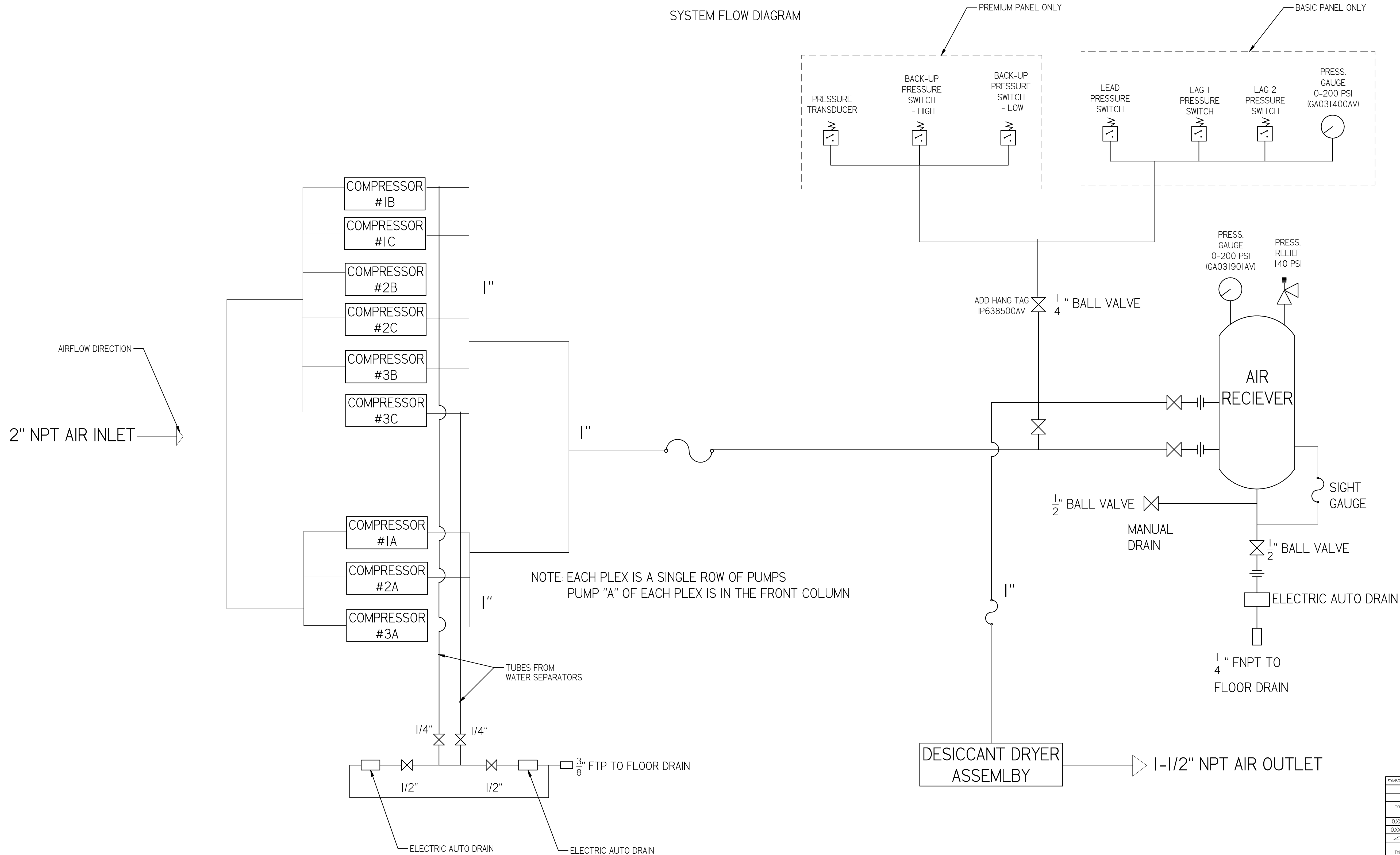

SYMBOL LEGEND		DRAWINGS TO CONFORM TO CURRENT REVISION OF THE FOLLOWING ANSI STANDARDS:	
		Y14.3 MULTI AND SECTIONAL VIEW DIMS	
		Y14.5 DIMENSIONING AND TOLERANCING	
TOLERANCES NOT SPECIFIED	SOLID EDGE DRAWING	DO NOT SCALE DRAWING FOR DIMENSIONS	
0.XXX ± .01		SHEET 3 OF 5	SCALE   1:1
0.XXX ± .005	INCH		
± .5			
<small>CONFIDENTIAL DISCLOSURE</small> This drawing is the property of POWEREX or the SCOTT FETTER COMPANY and is subject to return on demand. Its contents are confidential and must not be copied or submitted to outside parties for use or examination.		AUTHOR	APPROVALS ON FILE IN PLM
<small>FIGURE</small> 716081		ASoulek	11/5/2018
<small>MATERIAL</small> SEE PART NOTES			
<small>DESCRIPTION</small> MEDICAL OPEN SCROLL 15HP TRIPLEX WITH 120 GALLON TANK		<small>DRAWING NUMBER</small> MST15A4	<small>REVISION</small> B
			<b>D</b>







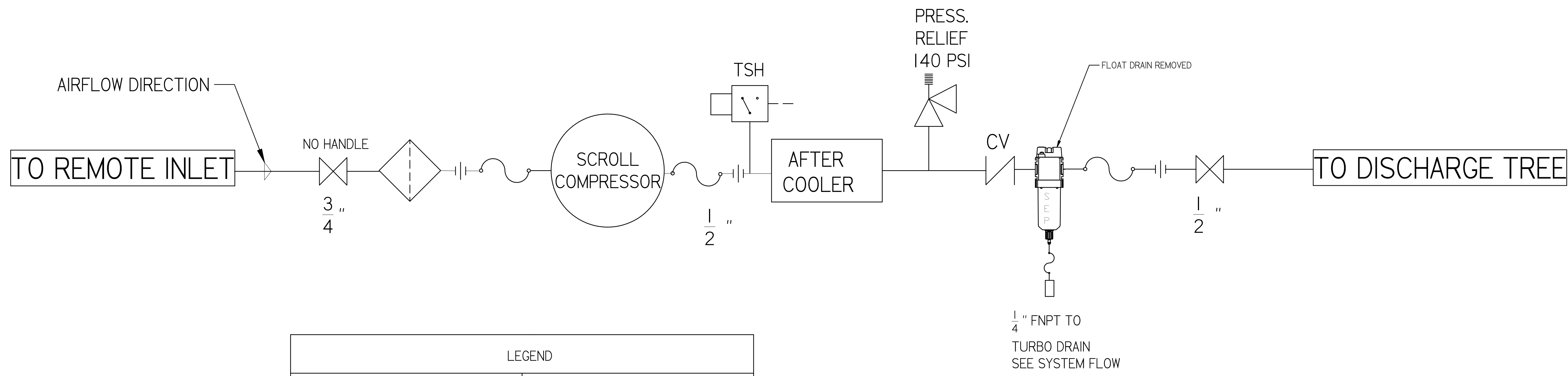

REVISION NOTES		
DESCRIPTION	ECN	PR/NOR
PRODUCTION RELEASE	PXECO169	N/A

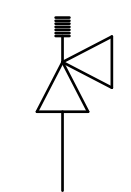
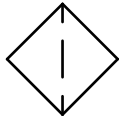
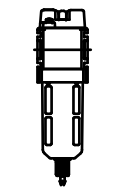
# MST15A4

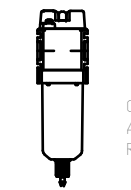
MEDICAL OPEN SCROLL 15HP  
TRIPLEX WITH 120 GALLON  
TANK  
MEDICAL COMPRESSOR  
FLOW DIAGRAM

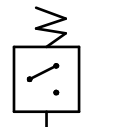
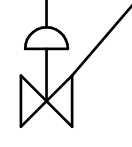
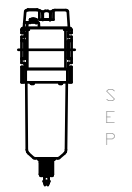

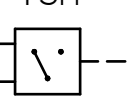
LEGEND	
	RELIEF VALVE
	INTAKE FILTER
	AIR FILTER
	3 WAY VALVE
	CARBON FILTER
	BALL VALVE
	PRESSURE SWITCH
	REGULATOR
	SEPARATOR
	CHECK VALVE
	FLEX LINE
	TSH HIGH TEMP SWITCH

SYMBOL LEGEND		DRAWINGS TO CONFORM TO CURRENT REVISION OF THE FOLLOWING ANSI STANDARDS:	
		Y14.3 MULTI AND SECTIONAL VIEW DWGS Y14.5 DIMENSIONING AND TOLERANCING	
TOLERANCES NOT SPECIFIED	SOLID EDGE DRAWING	DO NOT SCALE DRAWING FOR DIMENSIONS	
0.XXX ± .01	INCH	SHEET 4 OF 5	SCALE 1:1
0.XXX ± .005			
<small>CONFIDENTIAL DISCLOSURE</small> This drawing is the property of POWEREX of the SCOTT FETTER COMPANY and is subject to return on demand. Its contents are confidential and must not be copied or submitted to outside parties for use or examination.		AUTHOR	APPROVALS ON FILE IN PLM
TITLE: 716081 MATERIAL: SEE PART NOTES		ASoulek	11/5/2018
DESCRIPTION: MEDICAL OPEN SCROLL 15HP TRIPLEX WITH 120 GALLON TANK		DRAWING NUMBER: MST15A4	REVISION: B D



REVISION NOTES		
DESCRIPTION	ECN	PR/NOR
PRODUCTION RELEASE	PXECO169	N/A

# MST15A4

## MEDICAL OPEN SCROLL 15HP TRIPLEX WITH 120 GALLON TANK MEDICAL DRYER FLOW DIAGRAM

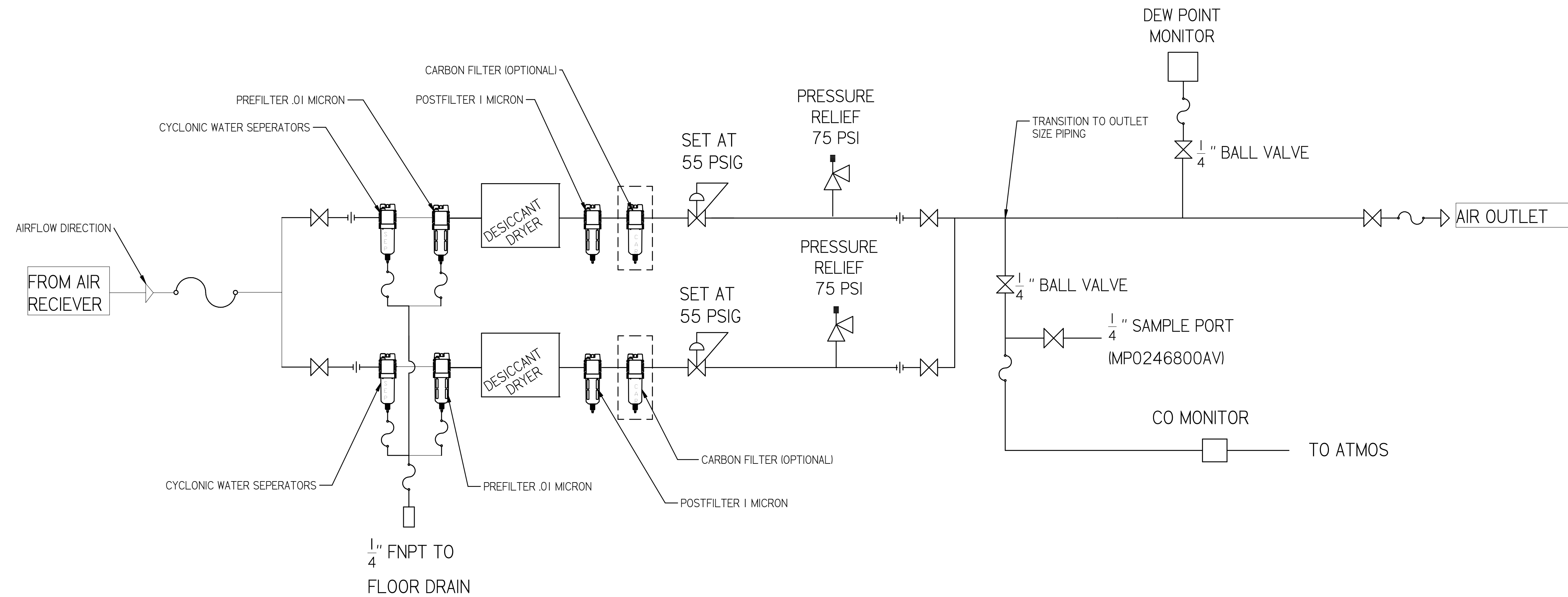

PIPE SIZE CHART		
PUMP COUNT	DRYER PLUMBING SIZE	OUTLET PIPE SIZE
2	1/2"	1/2"
3	1/2"	1"
4	1/2"	1"
6	1"	1-1/2"
8	1"	1-1/2"
9	1"	1-1/2"
12	1-1/2"	2"
15	1-1/2"	2"
18	1-1/2"	2"

SYMBOL LEGEND		DRAWINGS TO CONFORM TO CURRENT REVISION OF THE FOLLOWING ANSI STANDARDS: Y14.3 MULTI AND SECTIONAL VIEW DWGS Y14.5 DIMENSIONING AND TOLERANCING	
TOLERANCES NOT SPECIFIED	SOLID EDGE DRAWING	DO NOT SCALE DRAWING FOR DIMENSIONS	
0.XXX ± .01		SHEET 5 OF 5	SCALE 1:1
0.XXX ± .005	APPROVALS ON FILE IN PLM		
± .5		INCH	A Soulek
<small>CONFIDENTIAL DISCLOSURE</small> This drawing is the property of POWEREX or the SCOTT FETTER COMPANY and is subject to return on demand. Its contents are confidential and must not be copied or submitted to outside parties for use or examination.			
<small>ITEM NO:</small> 716081 <small>MATERIAL:</small> SEE PART NOTES		<small>DRAWING NUMBER:</small> MST15A4	<small>REVISION:</small> B <small>SIZE:</small> D

