

VOPD0403XPI

5HP OILLESS VACUUM
DUPLEX 80GAL

REVISION NOTES		
DESCRIPTION	ECN	PR/NOR
3D RELEASE	PXEC0293	N/A

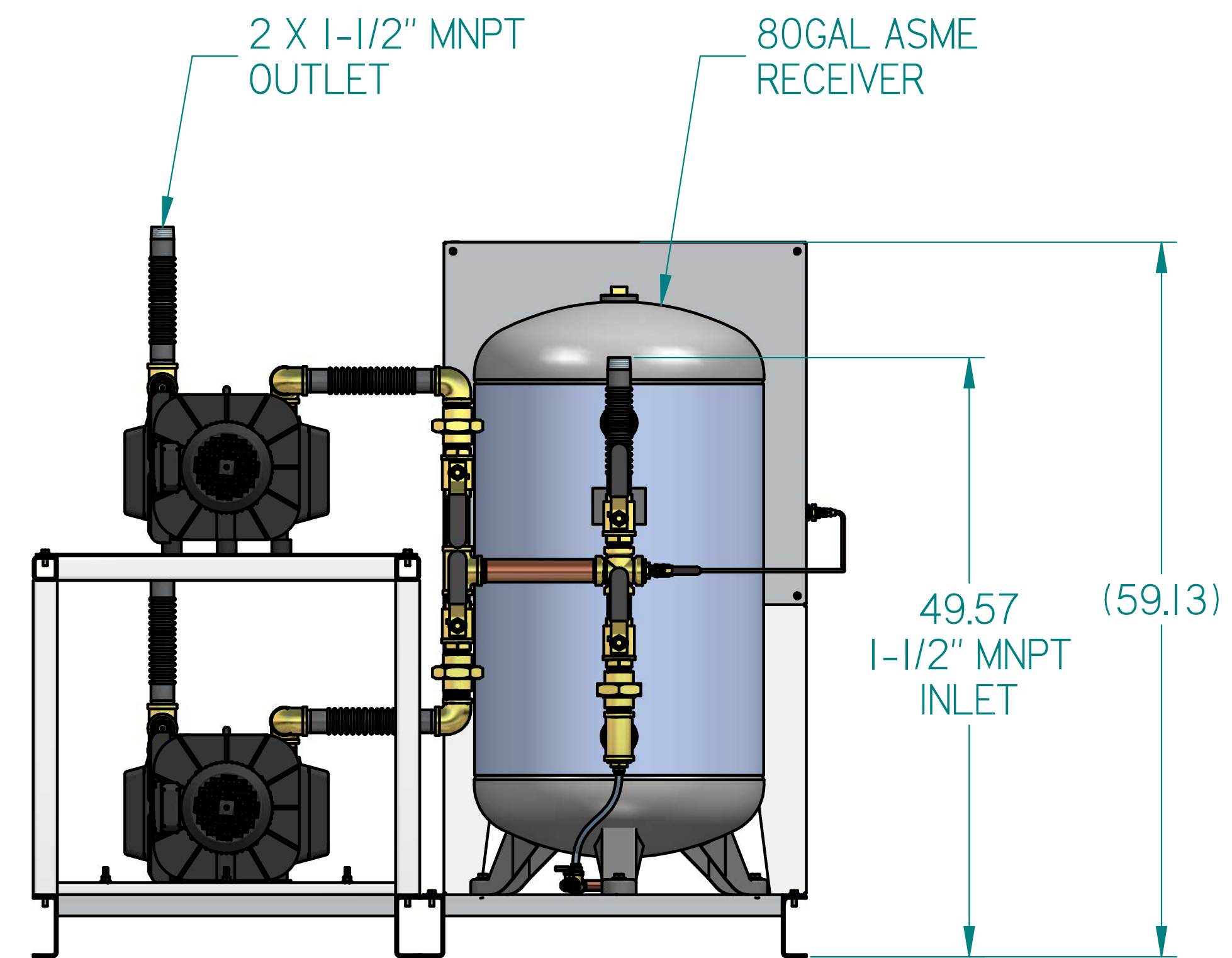
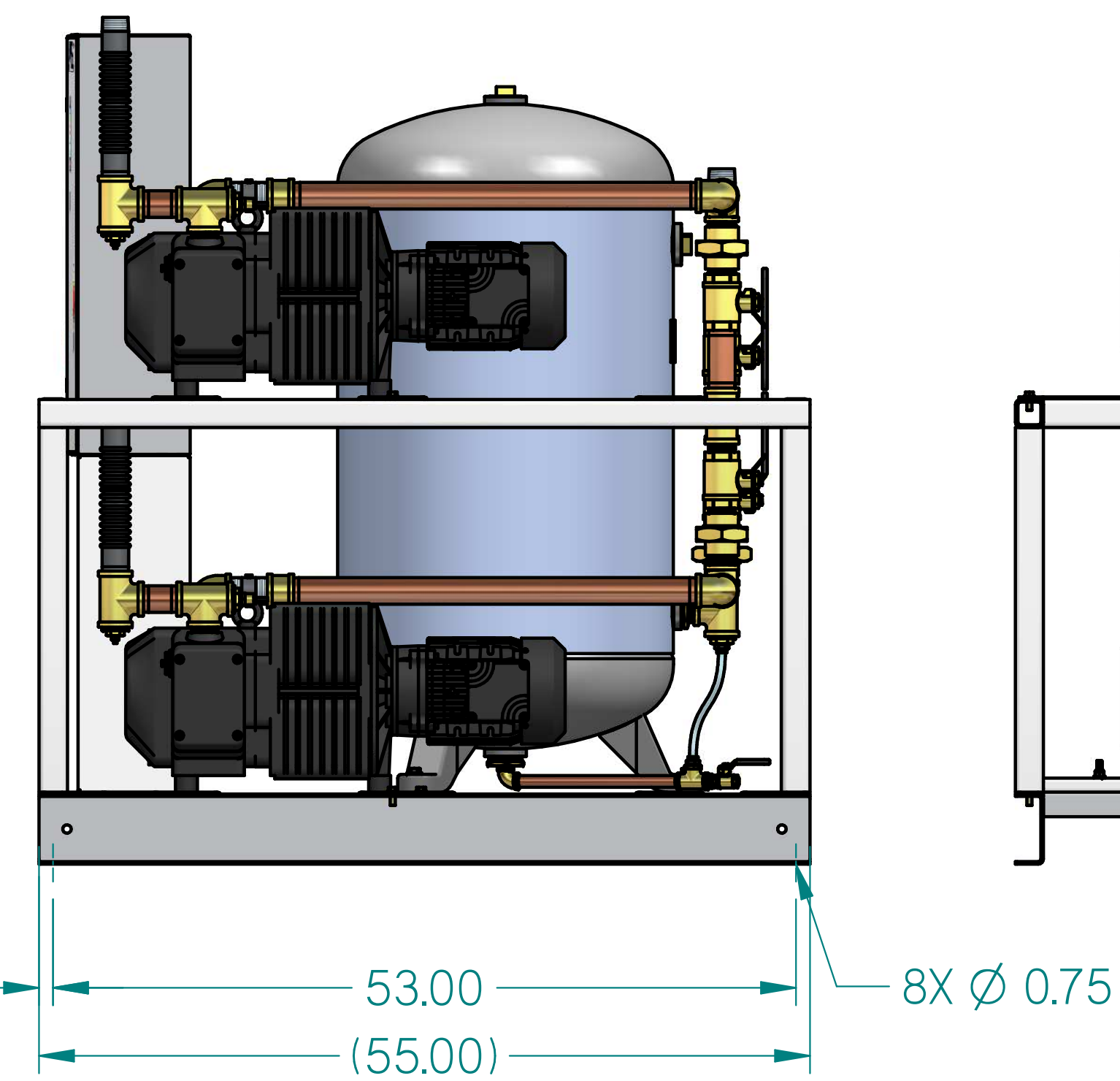
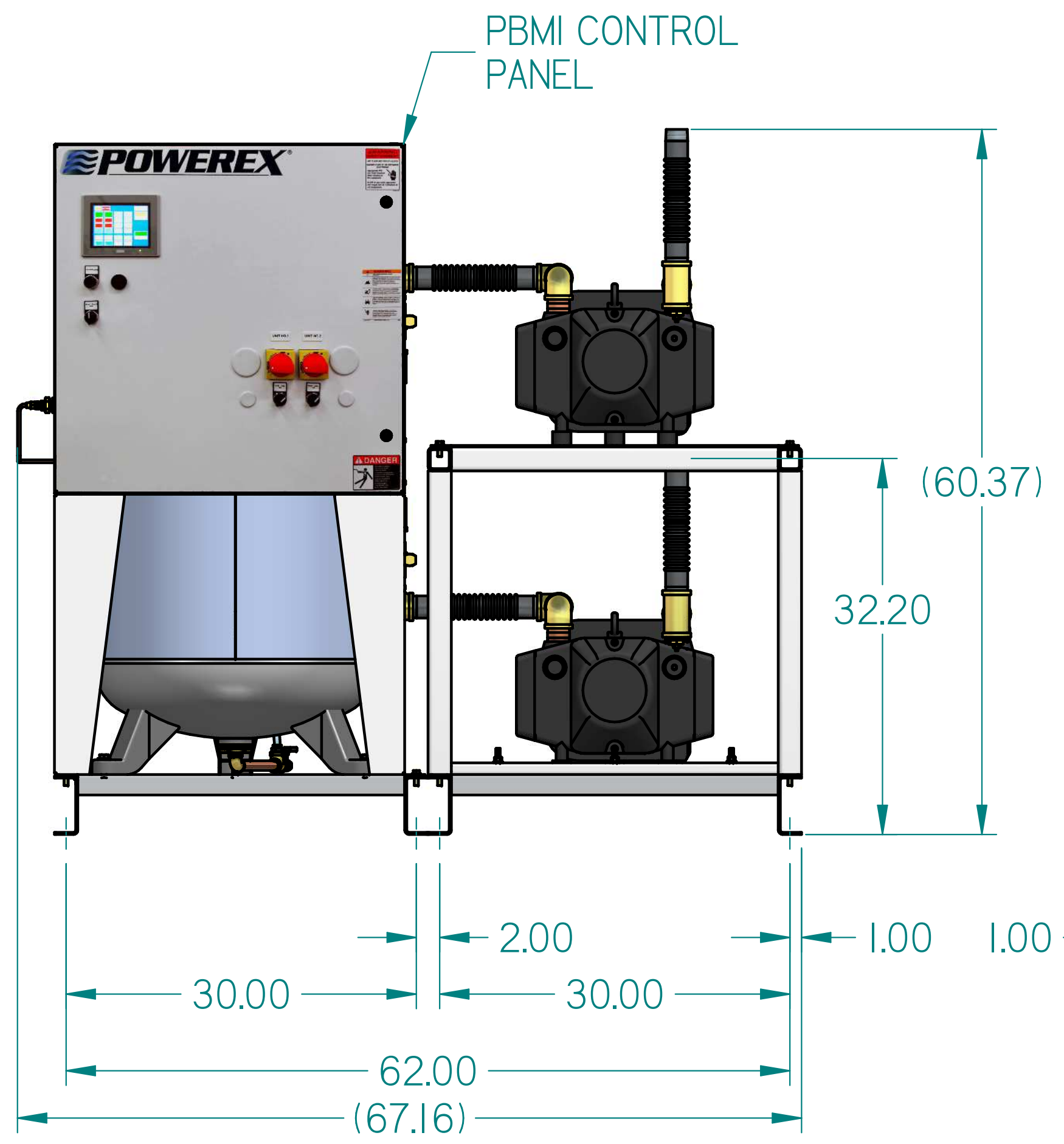
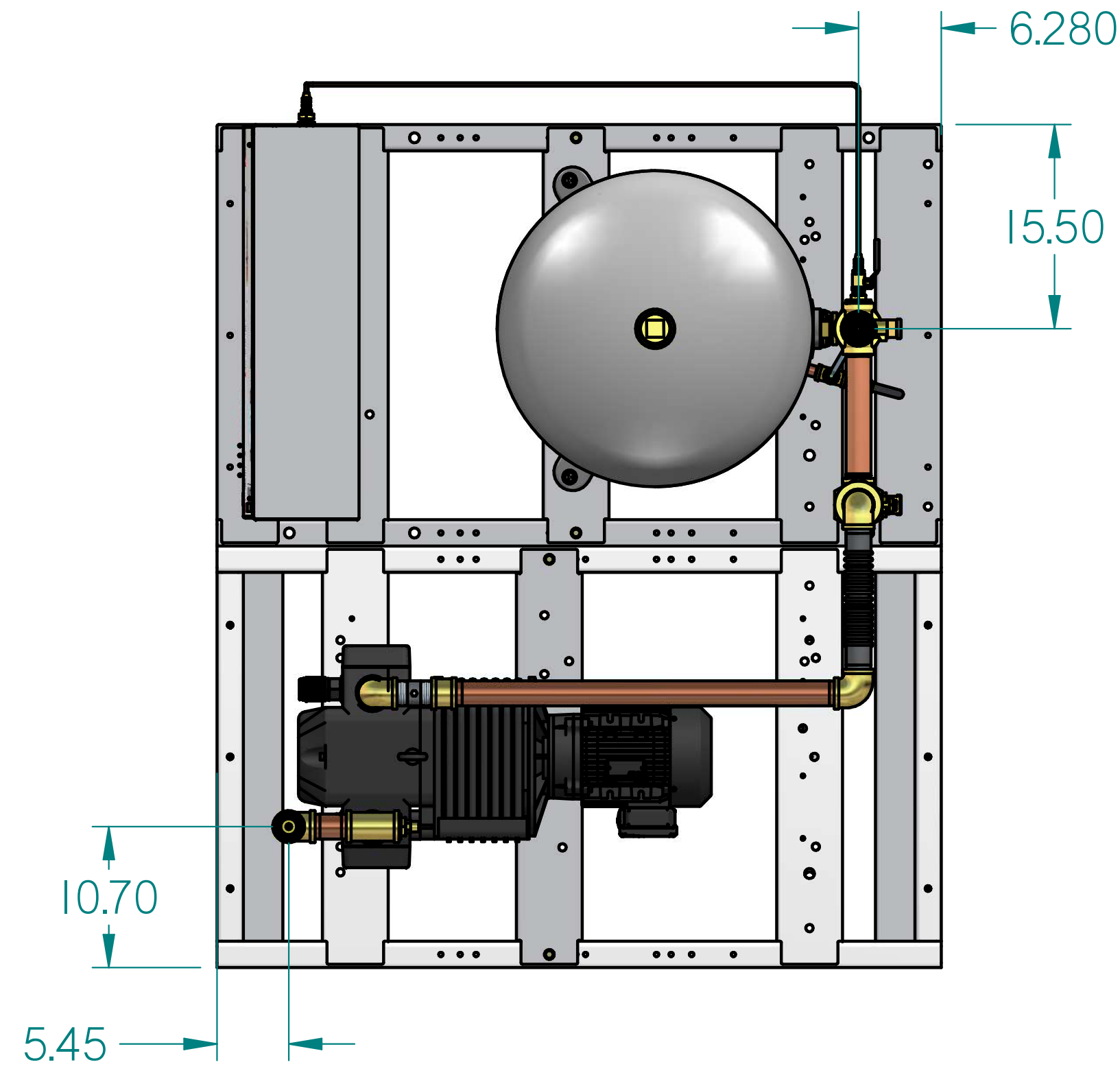

- NOTES:
1. APPROXIMATE WEIGHT: 1045 lbm
 2. A MINIMUM OF 24" CLEARANCE IS RECOMMENDED AROUND THE ENTIRE UNIT. CLEARANCE FOR CONTROL PANEL SHALL BE IN ACCORDANCE WITH OSHA/NEC REQUIREMENTS.
 3. SYSTEM DESIGNED IN COMPLIANCE WITH U.S. NFPA '99, LATEST EDITION.

SYMBOL LEGEND		DRAWINGS TO CONFORM TO CURRENT REVISION OF THE FOLLOWING ANSI STANDARDS:	
		#14.3 MULTI AND SECTIONAL VIEW DIMS	
		#14.5 DIMENSIONING AND TOLERANCING	
TOLERANCES NOT SPECIFIED:	SOLID EDGE DRAWING	DO NOT SCALE DRAWING FOR DIMENSIONS	
0.XXX ± .005			
0.XXX ± .010	INCH	SHEET 1 OF 2	SCALE 1:8
CONFIDENTIAL DISCLOSURE: This drawing is the property of POWEREX of the SCOTT FETTER COMPANY and is subject to return on demand. Its contents are confidential and must not be copied or submitted to outside parties for use or examination.		AUTHOR	APPROVALS ON FILE IN PLM
		TATA	28-02-2019
ITEM ID	POWEREX		
MATERIAL	ISO PRODUCTION DRIVE, HARRISON OH 45030 ISS: 7/26-7/27/19		
DESCRIPTION	DRAWING NUMBER	REVISION	SIZE
5HP OILLESS VACUUM DUPLEX 80GAL	VOPD0403XPI		D



VOPD0403XPI

5HP OILLESS VACUUM
 DUPLEX 80GAL

REVISION NOTES

DESCRIPTION	ECN	PR/NOR
3D RELEASE	PXEC0293	N/A

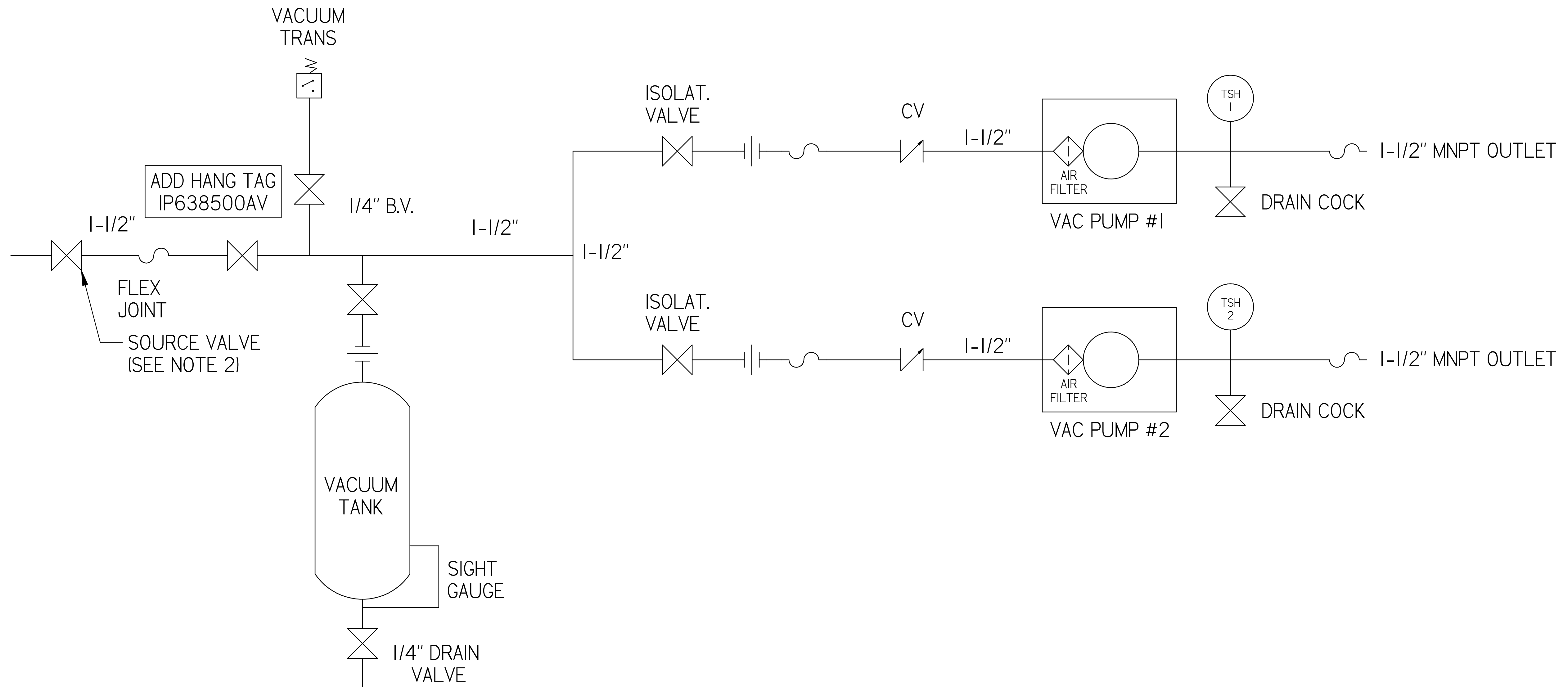

ADD HANG TAG
 IP638500AV

FLEX JOINT
 SOURCE VALVE
 (SEE NOTE 2)

VACUUM
 TRANS

1/4" B.V.

VACUUM
 TANK

SIGHT
 GAUGE

1/4" DRAIN
 VALVE

ISOLAT.
 VALVE

CV

1-1/2"

AIR
 FILTER

VAC PUMP #1

TSH
 1

DRAIN COCK

1-1/2" MNPT OUTLET

ISOLAT.
 VALVE

CV

1-1/2"

AIR
 FILTER

VAC PUMP #2

TSH
 2

DRAIN COCK

1-1/2" MNPT OUTLET

LEGEND

	TEMP. SWITCH		VACUUM SWITCH
	AIR FILTER		CHECK VALVE
	BALL VALVE		FLEX LINE
			UNION

NOTE:
 A 1/4 INCH VENT PLUG IS
 LOCATED IN THE FILTER HOUSING

- NOTES:
 1) TSH - TEMPERATURE SWITCH HIGH
 2) PER NFPA THE SYSTEM WILL REQUIRE A SOURCE VALVE (SUPPLIED BY OTHERS)

SYMBOL LEGEND		DRAWINGS TO CONFORM TO CURRENT REVISION OF THE FOLLOWING ANSI STANDARDS:	
TOLERANCES NOT SPECIFIED:		DO NOT SCALE DRAWING FOR DIMENSIONS	
0.001 ± .001	INCH	SHEET 2 OF 2	SCALE 1:1
CONFIDENTIAL DISCLOSURE: This drawing is the property of POWEREX or the SCOTT FETTER COMPANY and is subject to return on demand. Its contents are confidential and must not be copied or submitted to outside parties for use or examination.		AUTHOR	APPROVALS ON FILE IN PLM
ITEM ID		TATA	28-02-2019
MATERIAL		 150 PRODUCTION DRIVE, HARRISON OH 45030 (888) 768-7079	
DESCRIPTION 5HP OILLESS VACUUM DUPLEX 80GAL		DRAWING NUMBER VOPD0403XPI	REVISION D