

# VPT0754PI

7.5HP VACUUM 120GAL  
TRIPLEX

REVISION NOTES		
DESCRIPTION	ECN	PR/NOR
3D RELEASE	PXEC0293	N/A

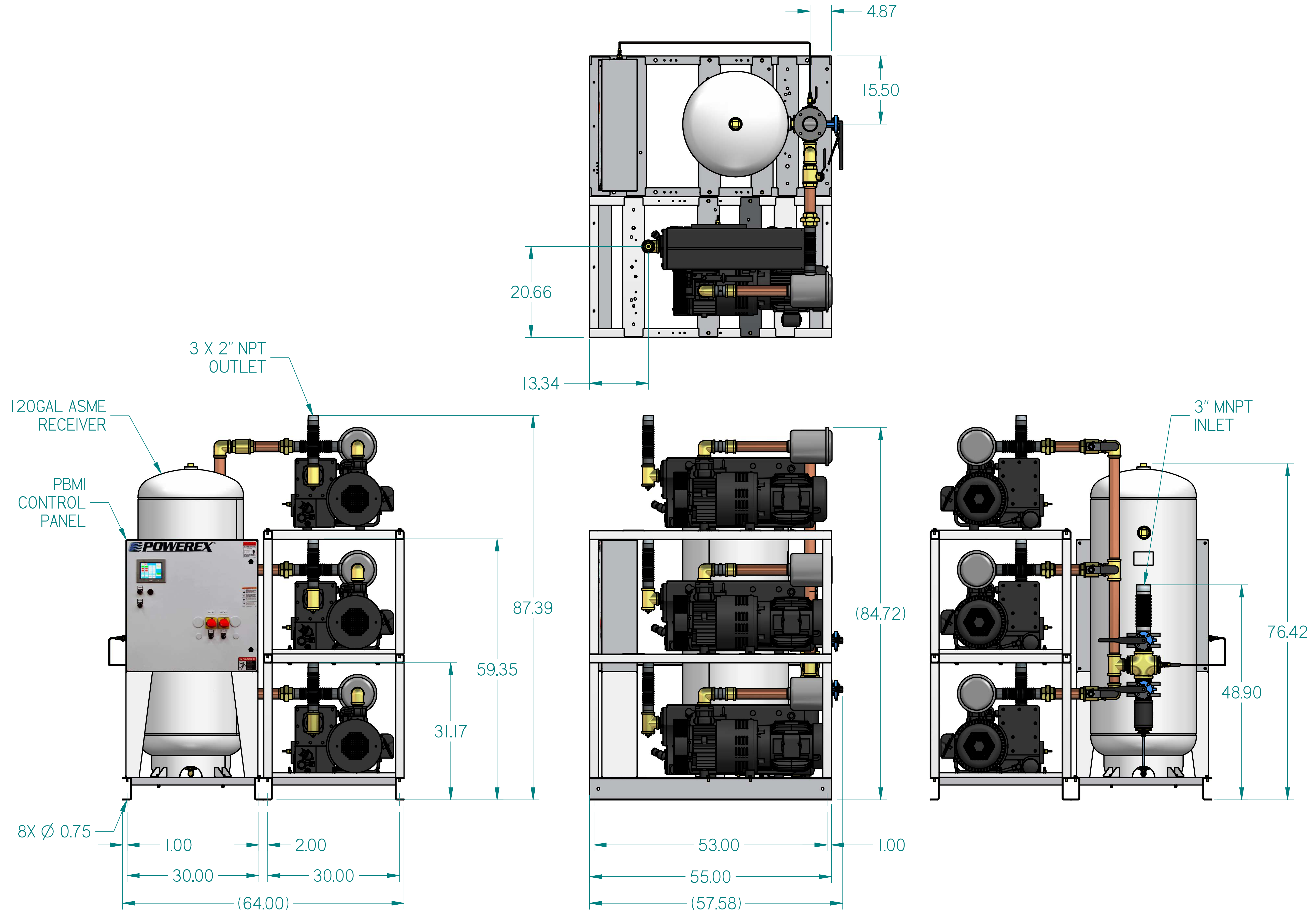

- NOTES:
1. APPROXIMATE WEIGHT: 7965 lbm
  2. A MINIMUM OF 24" CLEARANCE IS RECOMMENDED AROUND THE ENTIRE UNIT. CLEARANCE FOR CONTROL PANEL SHALL BE IN ACCORDANCE WITH OSHA/NEC REQUIREMENTS.
  3. SYSTEM DESIGNED IN COMPLIANCE WITH U.S. NFPA '99, LATEST EDITION.

SYMBOL LEGEND		DRAWINGS TO CONFORM TO CURRENT REVISION OF THE FOLLOWING ANSI STANDARDS:	
		Y14.3 MULTI AND SECTIONAL VIEW DWGS	
		Y14.5 DIMENSIONING AND TOLERANCING	
TOLERANCES NOT SPECIFIED	SOLID EDGE DRAWING	DO NOT SCALE DRAWING FOR DIMENSIONS	
0.004 ± .005		SHEET 1 OF 2	SCALE 1:8
0.0005 ± .001	INCH		
CONFIDENTIAL DISCLOSURE		APPROVALS ON FILE IN PLM	
This drawing is the property of POWEREX of the SCOTT FETTER COMPANY and is subject to return on demand. Its contents are confidential and must not be copied or submitted to outside parties for use or examination.		AUTHOR	ORIGINATION DATE
		TATA	01-03-2019
ITEM ID	POWEREX		
MATERIAL	ISO PRODUCTION DRIVE, HARRISON OH 45030		
		ISS: 768-7079	
DESCRIPTION	DRAWING NUMBER	REVISION	SIZE
7.5HP VACUUM 120GAL TRIPLEX	VPT0754PI		D



# VPT0754PI

7.5HP VACUUM 120GAL  
TRIPLEX

REVISION NOTES		
DESCRIPTION	ECN	PR/NOR
3D RELEASE	PXEC0293	N/A

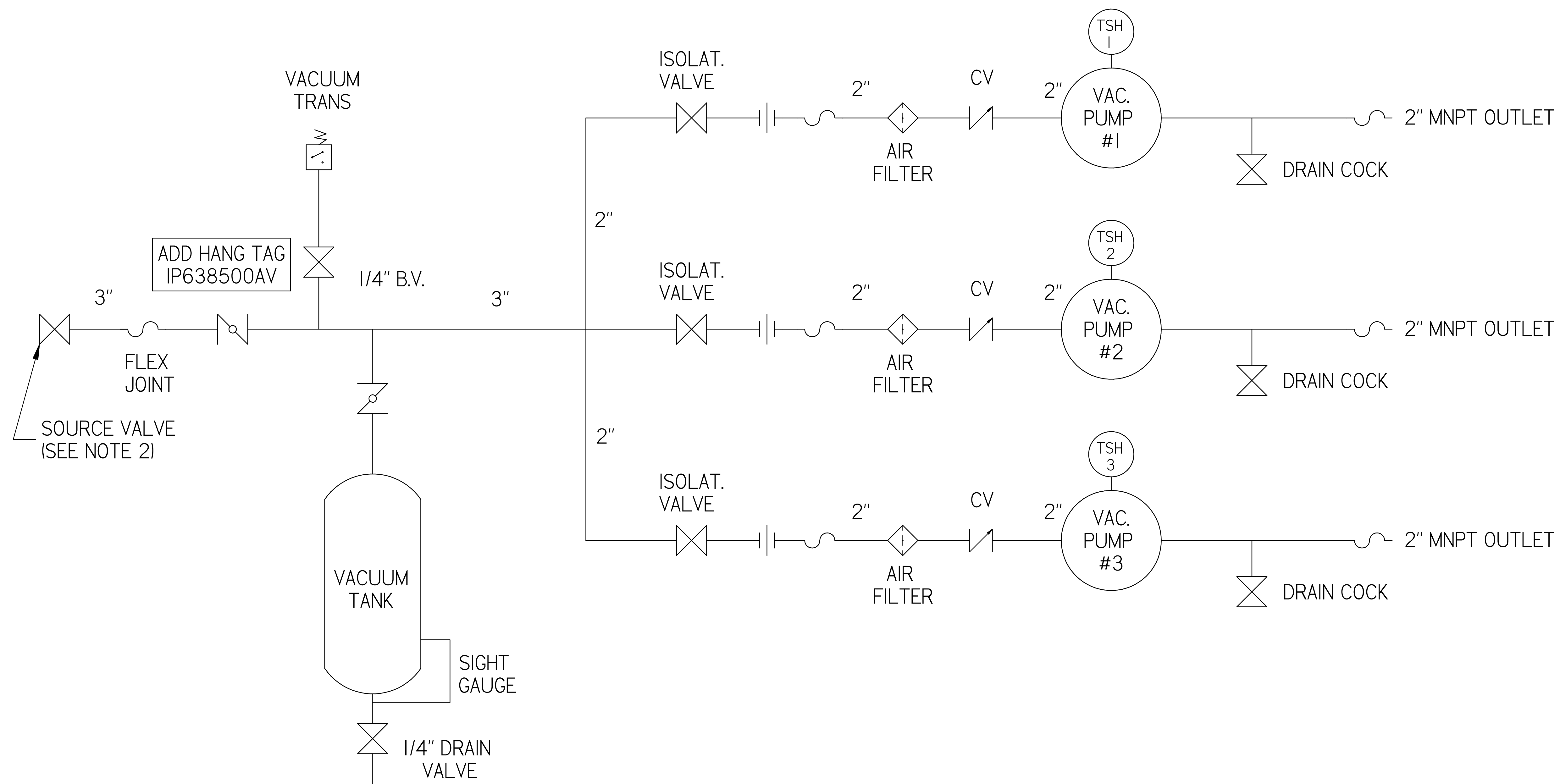

### LEGEND

	TEMP. SWITCH		VACUUM SWITCH
	AIR FILTER		CHECK VALVE
	BALL VALVE		FLEX LINE
	BUTTERFLY VALVE		UNION

NOTE:  
A 1/4 INCH VENT PLUG IS  
LOCATED IN THE FILTER HOUSING

- NOTES:  
1) TSH - TEMPERATURE SWITCH HIGH  
2) PER NFPA THE SYSTEM WILL REQUIRE A SOURCE VALVE (SUPPLIED BY OTHERS)

SYMBOL LEGEND		DRAWINGS TO CONFORM TO CURRENT REVISION OF THE FOLLOWING ANSI STANDARDS: #14.3 MULTI AND SECTIONAL VIEW DWGS #14.5 DIMENSIONING AND TOLERANCING	
TOLERANCES NOT SPECIFIED	SOLID EDGE DRAWING	DO NOT SCALE DRAWING FOR DIMENSIONS	
0.001 ± .001	INCH	SHEET 2 OF 2	SCALE 1:1
CONFIDENTIAL DISCLOSURE This drawing is the property of POWEREX of the SCOTT FETTER COMPANY and is subject to return on demand. Its contents are confidential and must not be copied or submitted to outside parties for use or examination.		AUTHOR	APPROVALS ON FILE IN PLM
MATERIAL		TATA	01-03-2019
DESCRIPTION 7.5HP VACUUM 120GAL TRIPLEX		DRAWING NUMBER VPT0754PI	REVISION
			SIZE D