

REV	ZONE	REVISION	DATE	EDN	NAME	CHKD
B-1	ALL	RELEASE TO PRODUCTION	4/23/13	PRE0010	RK	AEK
C-1	ALL	UPDATED TO WIND DRIVERS	9/8/17	PRE0014	AEK	GES
D-1	ALL	UPDATED SKID/FILTER ADDED BRACKETS	2/8/18	PRE0028	MH	GES
E	ALL	UPDATED DESIGN PPINC	1/30/19	PRE0027	SJA	MH
F	ALL	CHANGED TO TROENT DRYERS, MORGANTON TANK MODEL	5/9/19	PRE0029	GES	MH

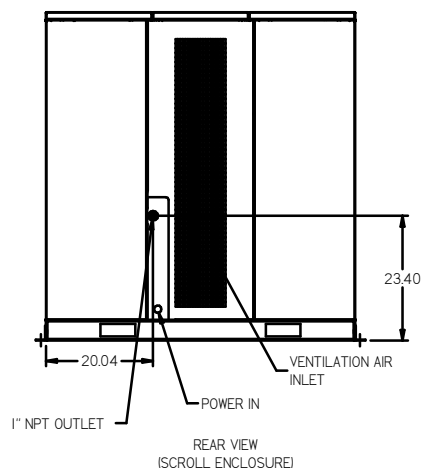
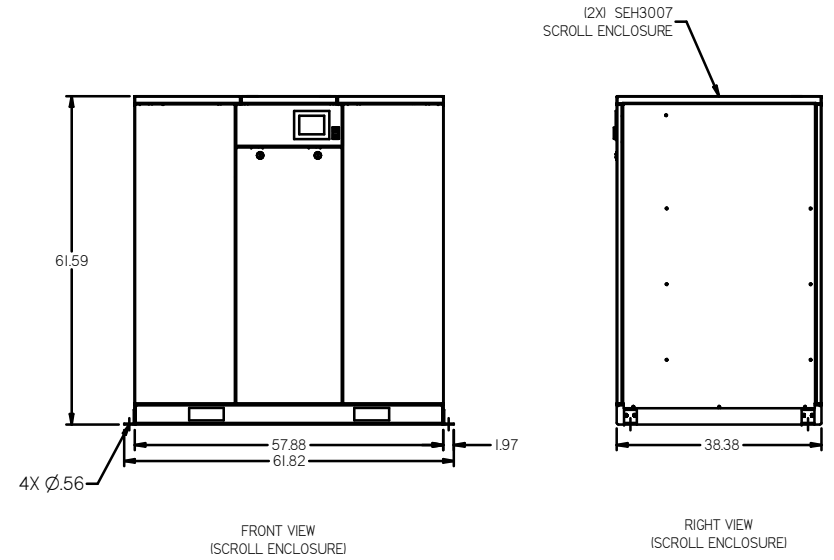
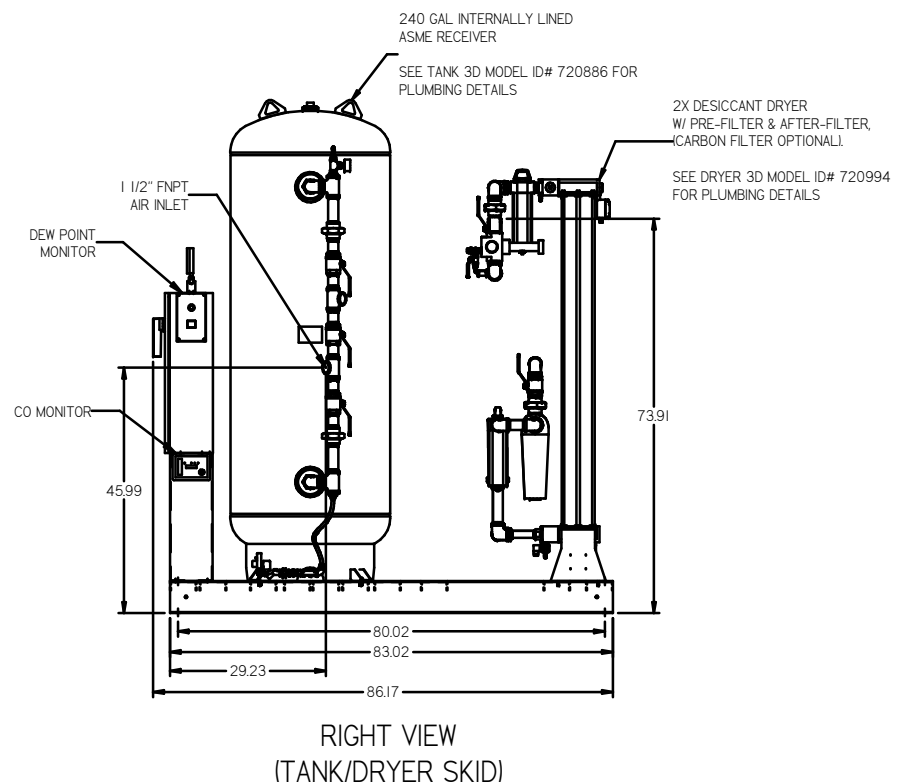
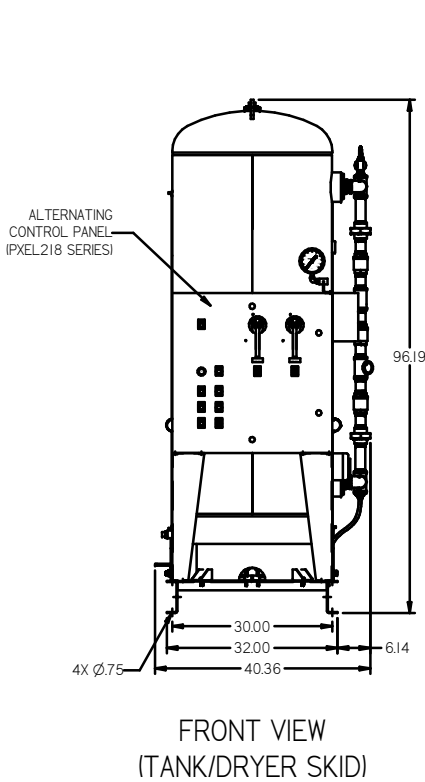
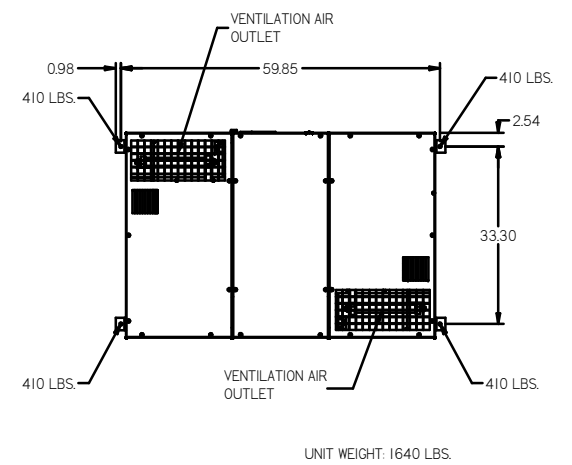
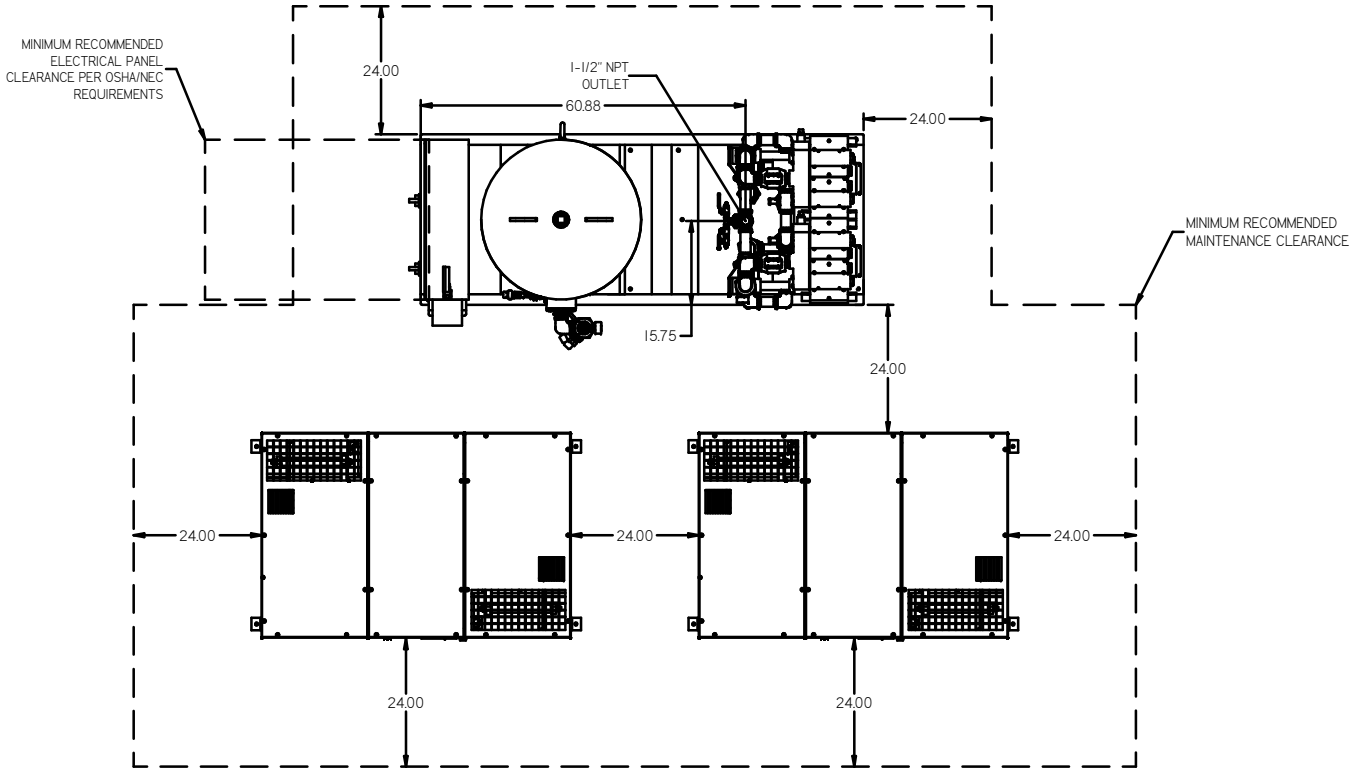

- NOTES:
- 1) SHEET 1, UNIT LAYOUT.
  - 2) SHEET 2, UNIT FLOW SCHEMATIC.
  - 3) OUTLET CONNECTION: (1) 1-1/2" FNPT.
  - 4) POWER CONNECTION: 1- 208, 230, OR 460 VOLT.
  - 5) SYSTEM DESIGNED IN COMPLIANCE WITH US NFPA'99, LATEST EDITION.

MINUS DRAFT PLUS DRAFT ADDITIONAL CONTROL BRINELL HARDNESS	AUTOCAD REL2008 LT INCH	DO NOT SCALE DRAWING FOR DIMENSIONS Sheet 1 of 2 SCALE 1:18
TOLERANCES NOT SPECIFIED XX = XXX = Z = REG. 3	CONFIDENTIAL DISCLOSURE This drawing is the property of the POWERREX, INC. or the SCOTT FETZER COMPANY and subject to return on demand. Its contents are confidential and must not be copied or submitted to outside parties. For use only as specified.	DRAWN BY: RK CHECKED BY: AEK APPROVED BY: JJA, CT DATES: 4/23/13, 4/23/13, 1/23/13, 4/23/13
MATERIAL: N/A PART NAME: 60HP ENCLOSE SCROLL 240GAL DUAL DESICCANT LAB PACKAGE		DWG NO: LSED3006 SIZE: D

REV	ZONE	REVISION	DATE	ECN	NAME	CHKD
B	ALL	RELEASED TO PRODUCTION	1/23/13		AEK	AEK
C-1	ALL	UPDATED TO NMD DRIVERS	9/8/17		PRECOIT4	AEK
D-1	ALL	UPDATED SKID/FLTR ASSES BRACKETS	2/8/18		PRECO228	MMH
E	ALL	UPDATED DESIGN PIPING	9/20/19		PRECO273	SJA
F	ALL	CHANGED TO TRIDENT DRIVERS, MORGANTON TANK MODEL	5/8/19		PRECO229	GES

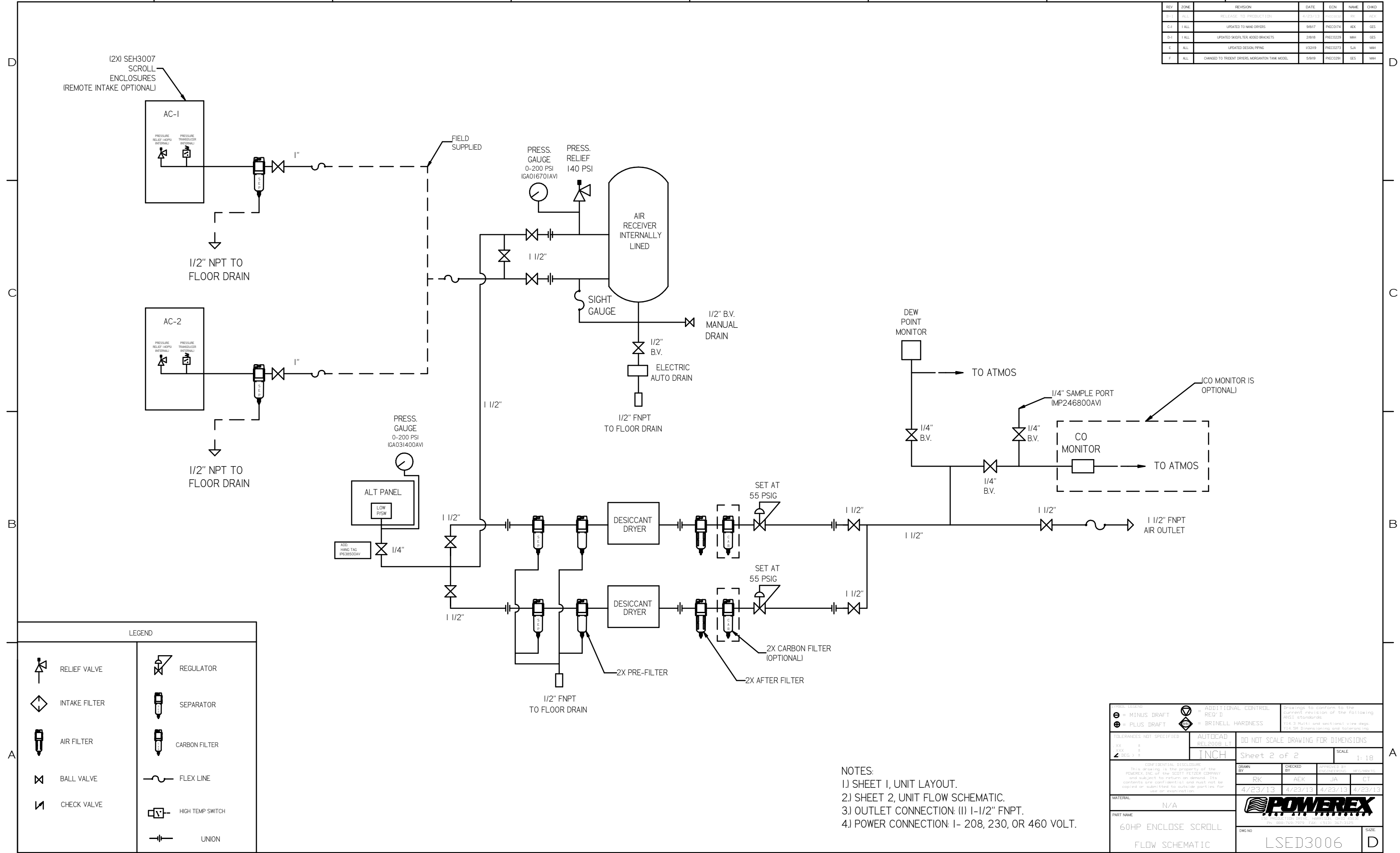

LEGEND	
	RELIEF VALVE
	INTAKE FILTER
	AIR FILTER
	BALL VALVE
	CHECK VALVE
	REGULATOR
	SEPARATOR
	CARBON FILTER
	FLEX LINE
	HIGH TEMP SWITCH
	UNION

- NOTES:  
 1.) SHEET 1, UNIT LAYOUT.  
 2.) SHEET 2, UNIT FLOW SCHEMATIC.  
 3.) OUTLET CONNECTION: (1) 1-1/2" FNPT.  
 4.) POWER CONNECTION: 1- 208, 230, OR 460 VOLT.

TOLERANCES NOT SPECIFIED XX ± XXX ± <math>\angle DEG > \pm	AUTOCAD REL2008.L1 INCH	DO NOT SCALE DRAWING FOR DIMENSIONS Sheet 2 of 2 SCALE 1:18
CONFIDENTIAL INFORMATION This drawing is the property of the POWEREX, INC. of the SCOTT FETZER COMPANY and subject to return on demand. Its contents are confidential and must not be copied or submitted to outside parties for use or examination.		DRAWN BY: RK CHECKED BY: AEK APPROVED BY: JA, CT DATE: 4/23/13, 4/23/13, 4/23/13, 4/23/13
MATERIAL: N/A PART NAME: 60HP ENCLOSE SCROLL FLOW SCHEMATIC		 150 PRODUCTION DRIVE, HARRISBURG, OHIO 45002 PH: 930-760-7923 FAX: 1-513-362-3125
DWG NO: LSED3006		SIZE: D