

General

Powerex Medical Vacuum Filter Assemblies are designed to protect the service professionals who perform maintenance on the vacuum units. The filters remove solid, liquid, and bacterial contamination as small as 0.3 micron out with 99.995% efficiency through HEPA-grade filters.

These systems must be used in conjunction with a medical vacuum system to be compliant with the 2018 revision of NFPA 99 (5.1.3.7.4), which requires the addition of inlet bacteriologic filtration at the medical vacuum source. Additionally, the systems meet ISO 7396-1 and HTM 02-01.*

The filter systems include:

- Multiple filters mounted to a metal frame
- Single point connections for inlet and outlet pipes
- Isolation valves on source side and patient side for each filter
- Clear Borosil glass flask to easily detect liquid accumulation

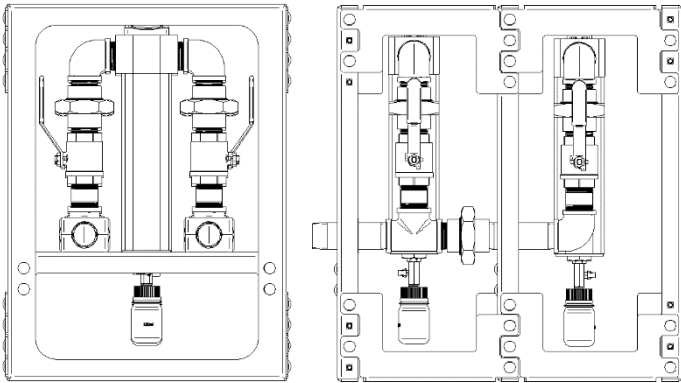

Model MVF20D

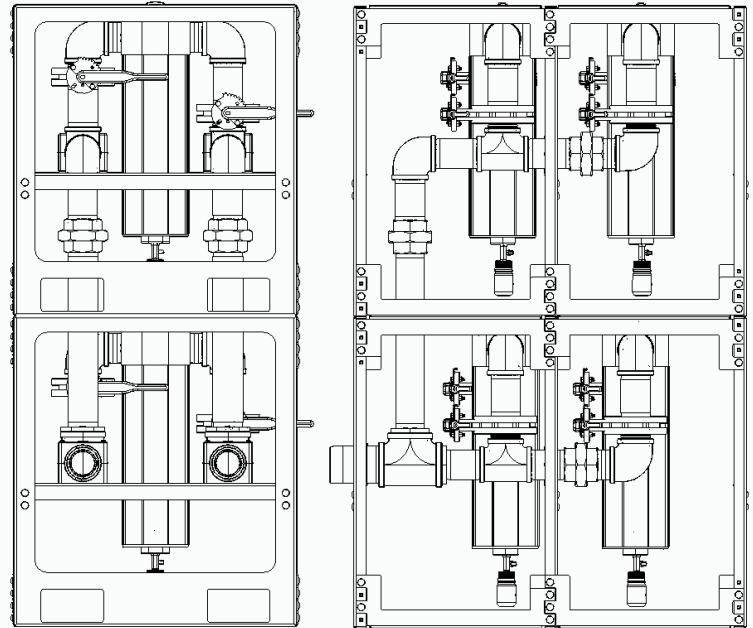

Model MVF40Q

Medical Vacuum Filter Assembly								
Model	SCFM @ 19 in Hg ¹	SCFM @ 15 in Hg ¹	Height (in)	Width (in)	Depth (in)	Inlet NPT Size	Outlet NPT Size	Approximate System Weight (lbs)
MVF15D*	21	28	27.0	21.0	27.0	1.5"	1.5"	135
MVF20D*	90	120	40.0	27.5	33.5	2"	2"	215
MVF30D*	173	230	37.5	36.5	49.5	3"	3"	437
MVF40T	346	460	37.5	36.5	72.5	4"	4"	685
MVF40Q*	519	690	75.5	36.5	50.5	4"	4"	985

Notes:

1 – CFM capacities are shown with reserve filters on standby per NFPA 99.

* HTM 02-01 requires full 100% redundancy. MVF15D, MVF20D, and MVF30D meet this standard. MVF40Q meets the standard when sized for 2 filters with 2 in reserve (reducing SCFM @ 19in Hg to 346, and SCFM @ 15in Hg to 460).