

VVOTD0504xP1

5 HP OILLESS VACUUM DUPLEX 120 GAL

REVISION NOTES		
DESCRIPTION	ECN	PR/NOR
UPDATED TEMPLATE AND FLOW DIAGRAM, ADDED DUAL DIMENSIONS	PXEC0428	

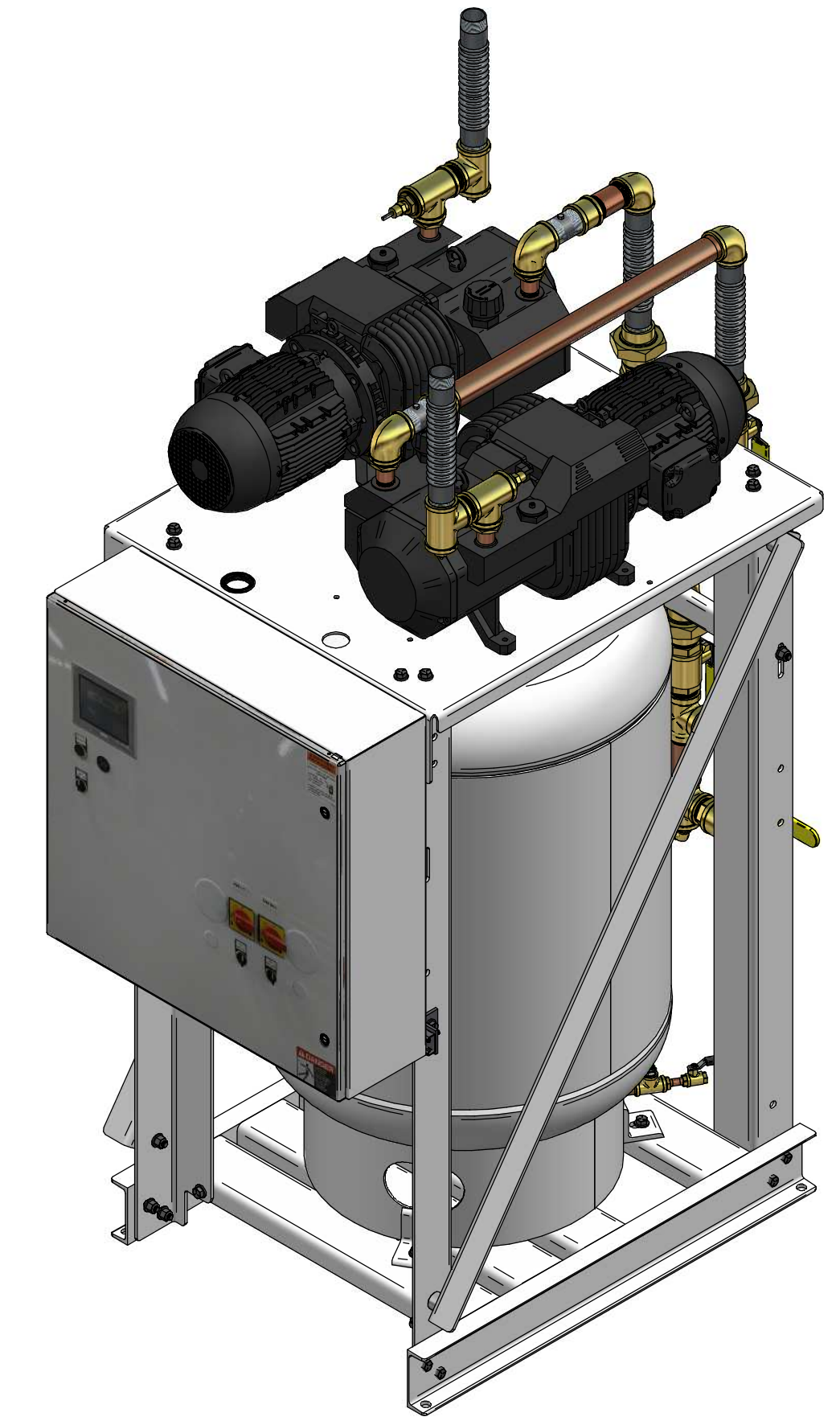
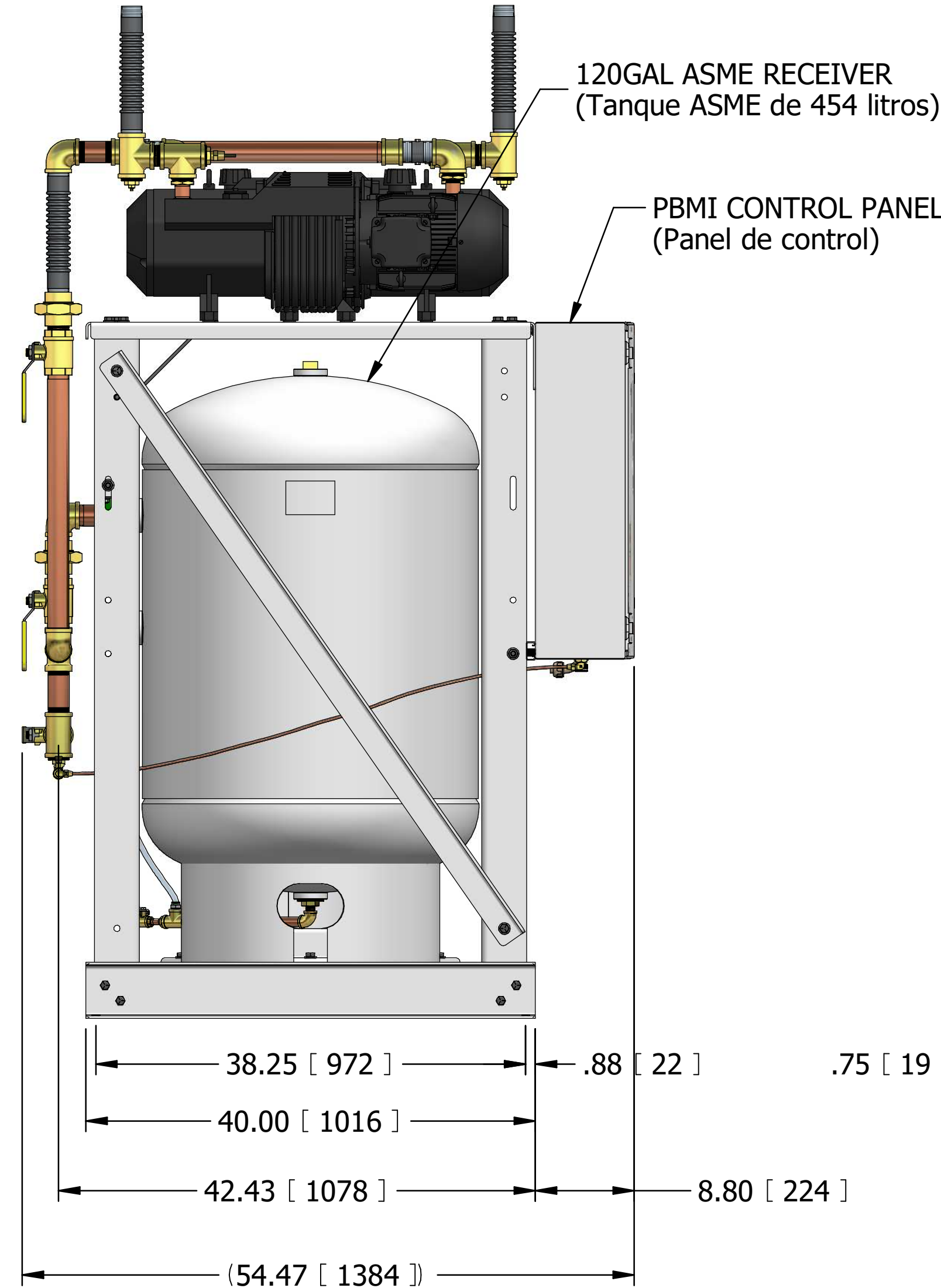
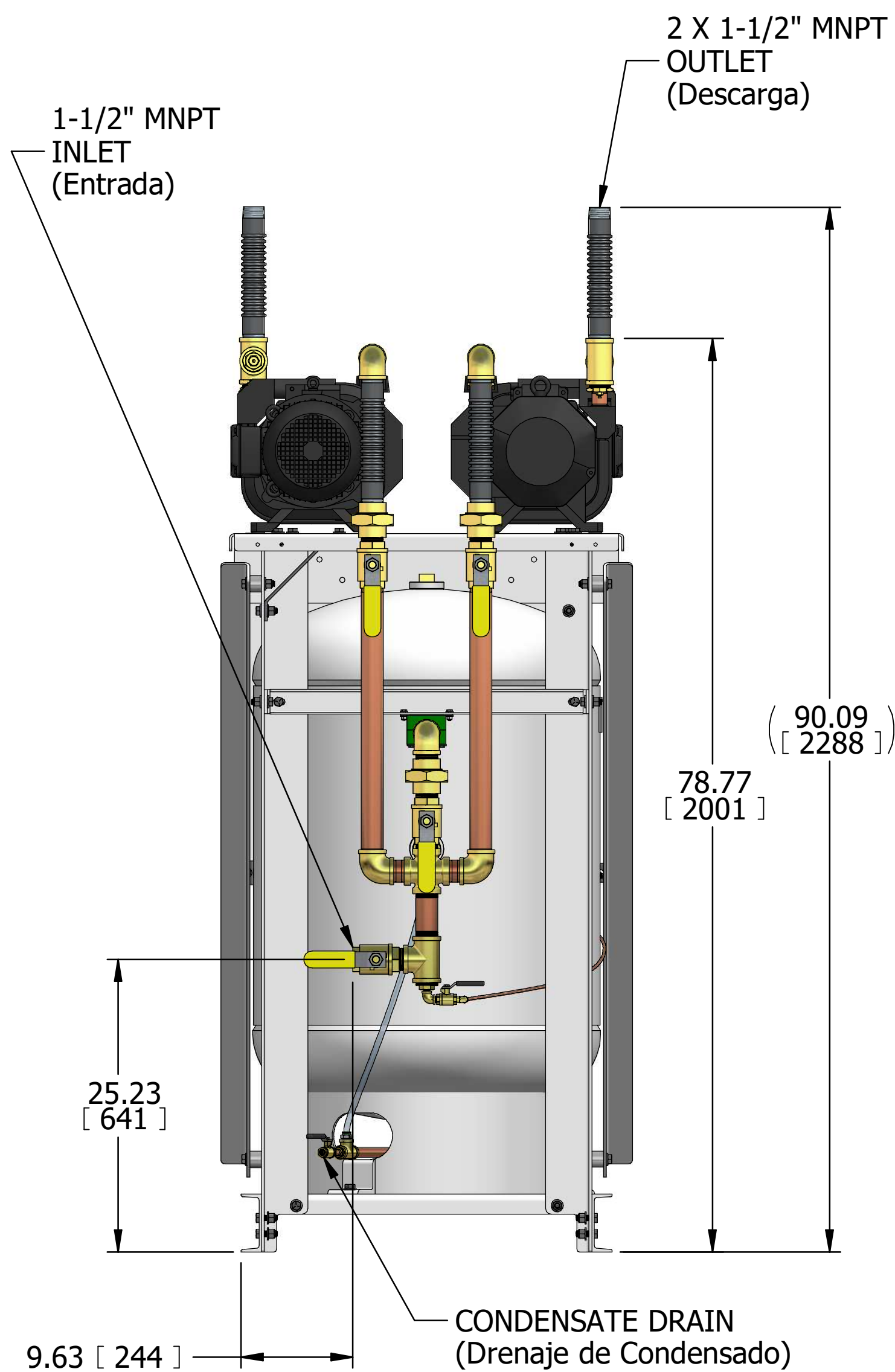
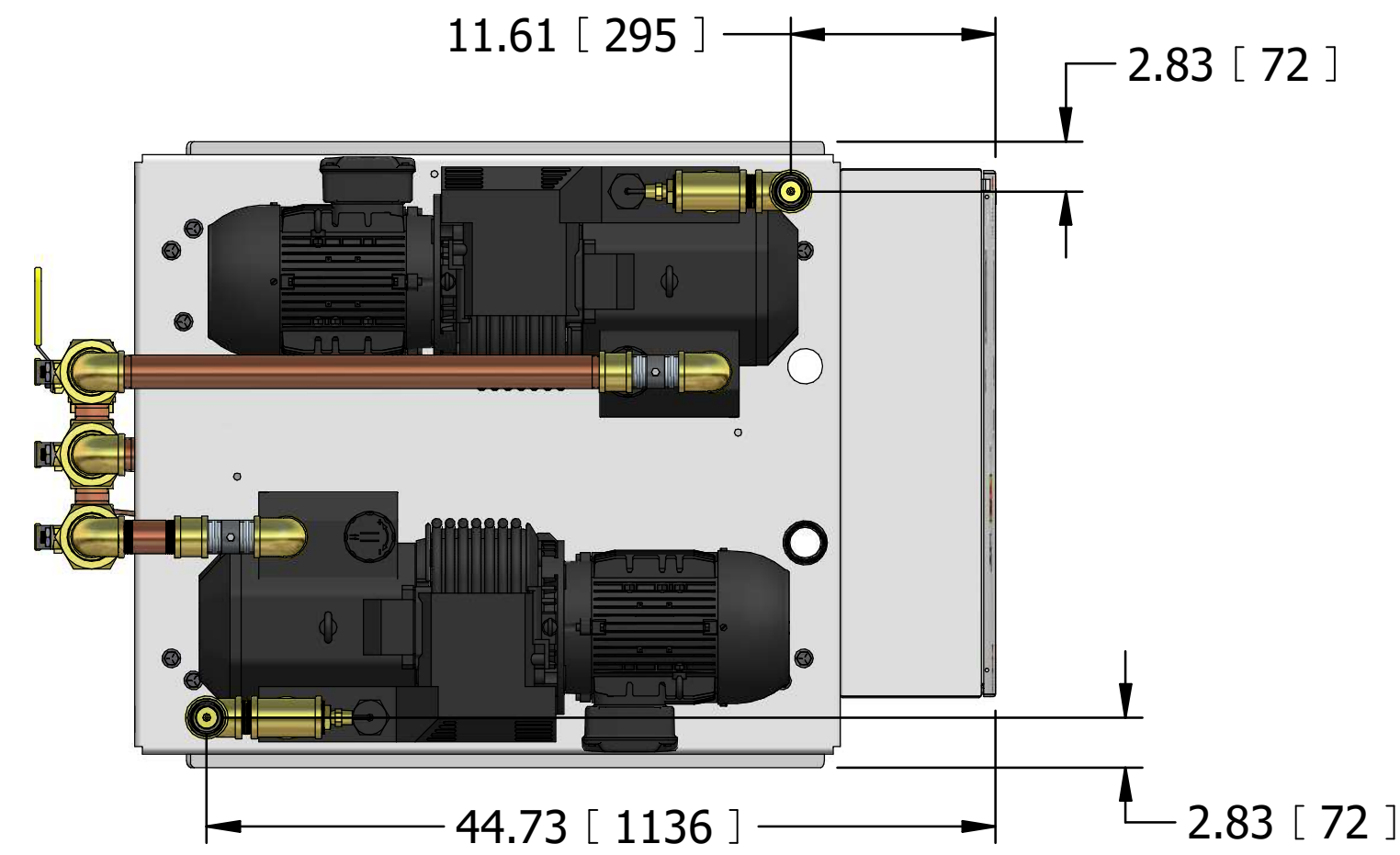

POWEREX™

- NOTES:
- APPROXIMATE WEIGHT: 1467 LBS
 - A MINIMUM OF 24" CLEARANCE IS RECOMMENDED AROUND THE ENTIRE UNIT. CLEARANCE FOR CONTROL PANEL SHALL BE IN ACCORDANCE WITH OSHA/NEC REQUIREMENTS.
 - SYSTEM DESIGNED IN COMPLIANCE WITH U.S. NFPA '99, LATEST EDITION.
- PESO APROXIMADO: 665 kg
 - RECOMENDAMOS QUE EL ESPACIO LIBRE ALREDEDOR DEL SISTEMA DEBE SER COMO MÍNIMO 24" (600 mm). EL ESPACIO LIBRE PARA EL TABLERO DE CONTROL DEBERÁ ESTAR DE ACUERDO CON LOS REQUERIMIENTOS DE SEGURIDAD DE LA OSHA/NEC.
 - EL SISTEMA ESTÁ DISEÑADO DE ACUERDO CON LA ÚLTIMA EDICIÓN DE LA NFPA 99.

SYMBOL LEGEND		DRAWINGS TO CONFORM TO CURRENT REVISION OF THE FOLLOWING AND STANDARDS:	
		Y14.3 MULTI AND SECTIONAL VIEW DWGS Y14.5 DIMENSIONING AND TOLERANCING	
TOLERANCES, UNLESS OTHERWISE SPECIFIED:	SOLID EDGE DRAWING	DO NOT SCALE DRAWING FOR DIMENSIONS	
0.XXX ± .005			
0.XXX ± .005			
± .1	INCH [mm]	SHEET 1 OF 2	SCALE 1:10
CONFIDENTIAL DISCLOSURE This drawing is the property of POWEREX of the SCOTT FEZTER COMPANY and is subject to return on demand. Its contents are confidential and must not be copied or submitted to outside parties for use or examination.		AUTHOR	REVISION DATE
		TATA	5/26/2021
ITEM NO: 719609		APPROVALS ON FILE IN PLM	
MATERIAL: ---		POWEREX™	
		150 PRODUCTION DRIVE, HARRISON OH 45030 (888) 769-7979	
DESCRIPTION	DRAWING NUMBER	REVISION	SIZE
5 HP OILLESS VACUUM DUPLEX 120 GAL	VVOTD0504xP1	B	D

VVOTD0504xP1

5 HP OILLESS VACUUM DUPLEX 120 GAL

REVISION NOTES		
DESCRIPTION	ECN	PR/NOR
UPDATED TEMPLATE AND FLOW DIAGRAM, ADDED DUAL DIMENSIONS	PXEC0428	

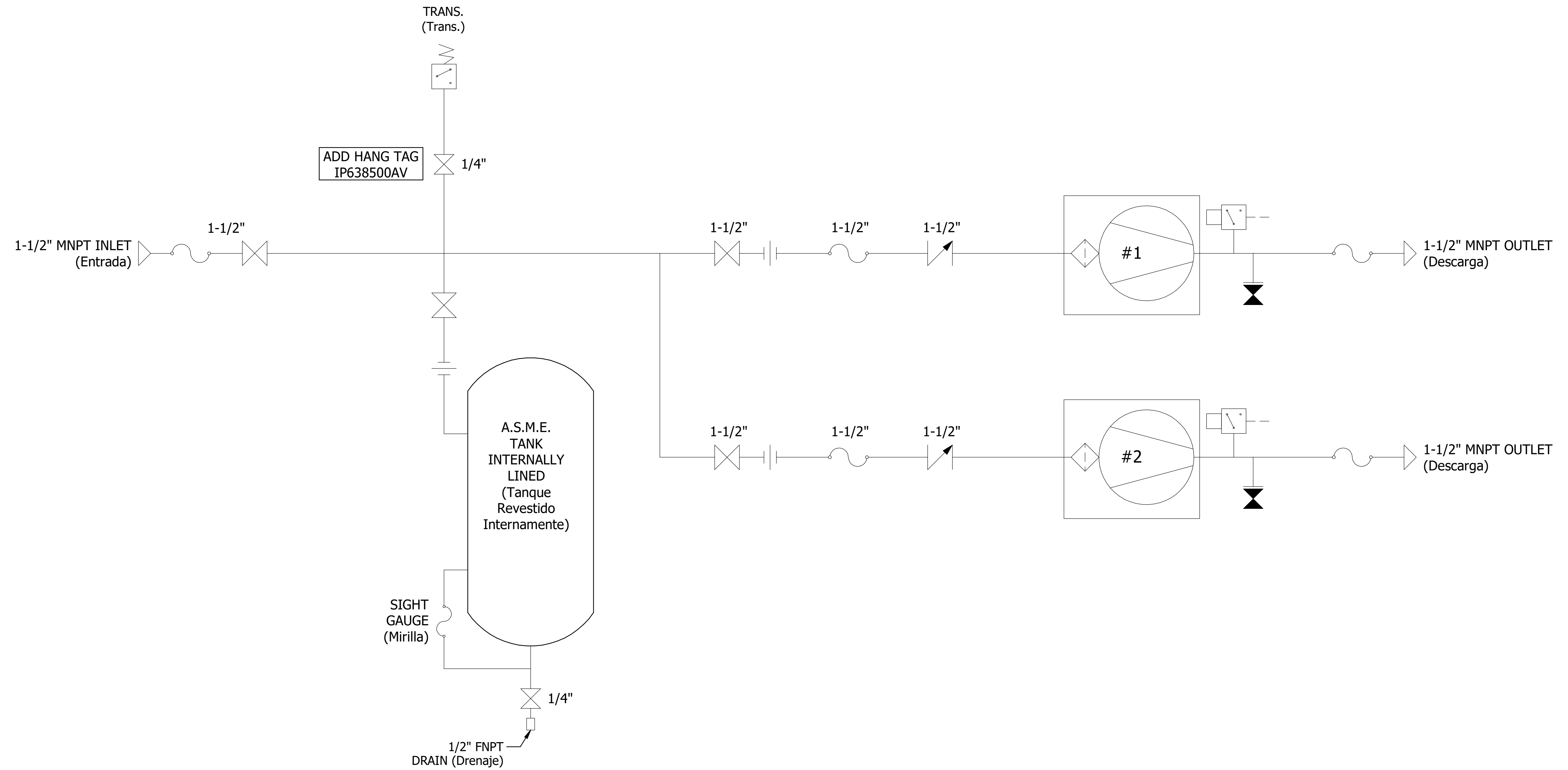

POWEREX™

LEGEND (Leyenda)

<p> CHECK VALVE (Válvula Cheque)</p> <p> BALL VALVE (Válvula de Bola)</p> <p> INTAKE FILTER (Filtro admisión)</p> <p> GAUGE (Manómetro)</p> <p> UNION (Unión)</p> <p> DRAIN COCK (Grifo de Drenaje)</p> <p> AIR LINE (Tubería de Aire)</p>	<p> VACUUM PUMP (Bomba de Succión)</p> <p> BUTTERFLY VALVE (Válvula de Mariposa)</p> <p> FLEX HOSE (Manguera flexible)</p> <p> TEMPERTURE SWITCH (Interruptor temperatura)</p> <p> VACUUM SWITCH/TRANSDUCER (Interruptor/Transductor vacío)</p> <p> SOLENOID VALVE (Válvula solenoide)</p> <p> CONDENSATE LINE (Línea de Condensado)</p>
--	--

SYMBOL LEGEND		DRAWINGS TO CONFORM TO CURRENT REVISION OF THE FOLLOWING STANDARDS:	
		Y14.1 MULTI AND SECTIONAL VIEW DWGS	
		Y14.5 DIMENSIONING AND TOLERANCING	
TOLERANCES, UNLESS OTHERWISE SPECIFIED:		DO NOT SCALE DRAWING FOR DIMENSIONS	
0.XX ± .005			
0.XXX ± .005			
± .1		SHEET 2 OF 2	SCALE 1:1
CONFIDENTIAL DISCLOSURE		APPROVALS ON FILE IN PLM	
This drawing is the property of POWEREX of the SCOTT FEZTER COMPANY and is subject to return on demand. Its contents are confidential and must not be copied or submitted to outside parties for use or examination.		AUTHOR	REVISION DATE
		TATA	5/26/2021
ITEM NO: 719609		POWEREX™	
MATERIAL: ---		150 PRODUCTION DRIVE, HARRISON OH 45030 (888) 769-7979	
DESCRIPTION: 5 HP OILLESS VACUUM DUPLEX 120 GAL		DRAWING NUMBER: VVOTD0504xP1	REVISION: B SIZE: D

VVOTD0504K1

5 HP OILLESS VACUUM DUPLEX 120 GAL

REVISION NOTES		
DESCRIPTION	ECN	PR/NOR
UPDATED DRAWING FOR DUAL DIMENSIONS	PXEC0428	

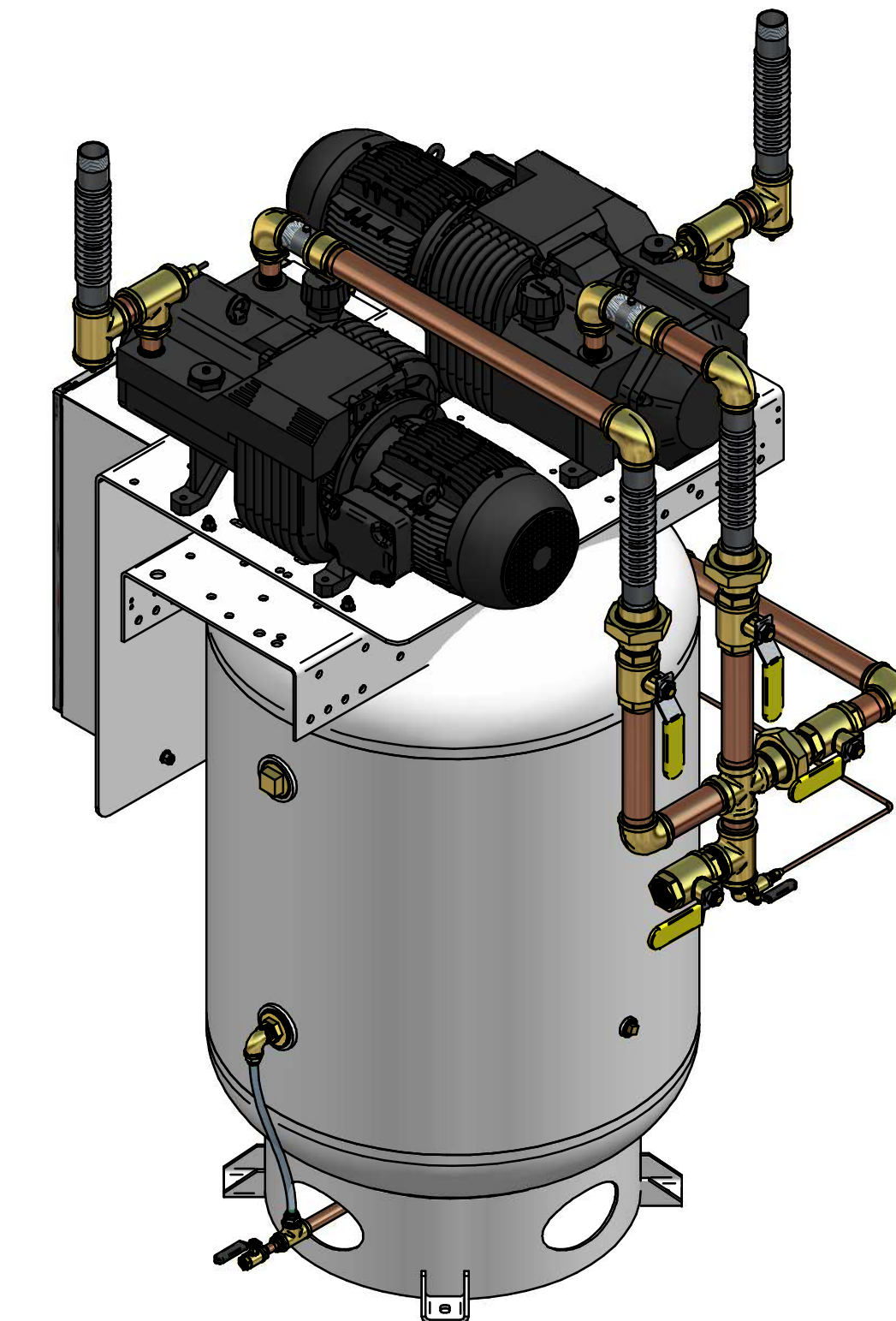
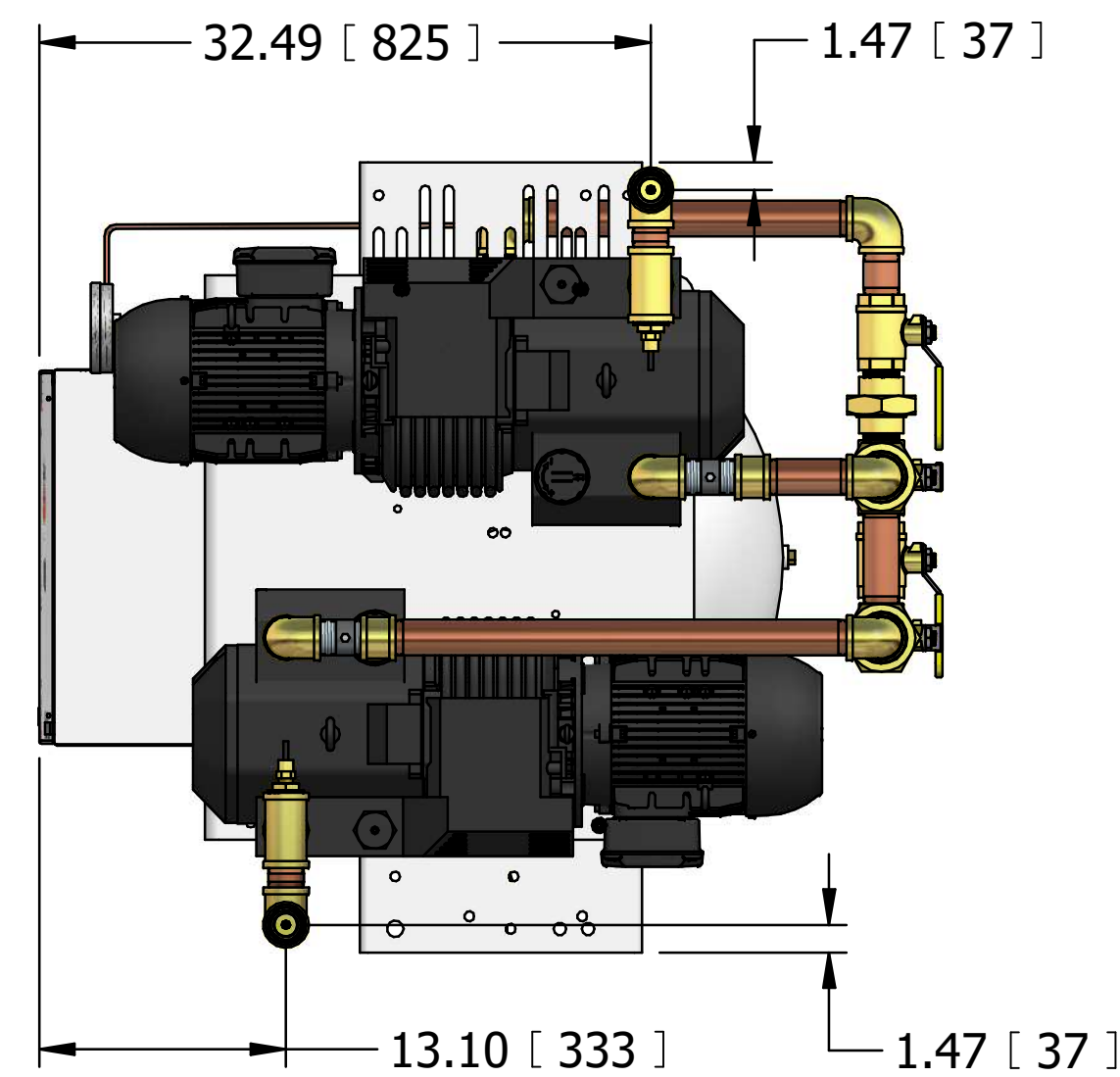

POWEREX™

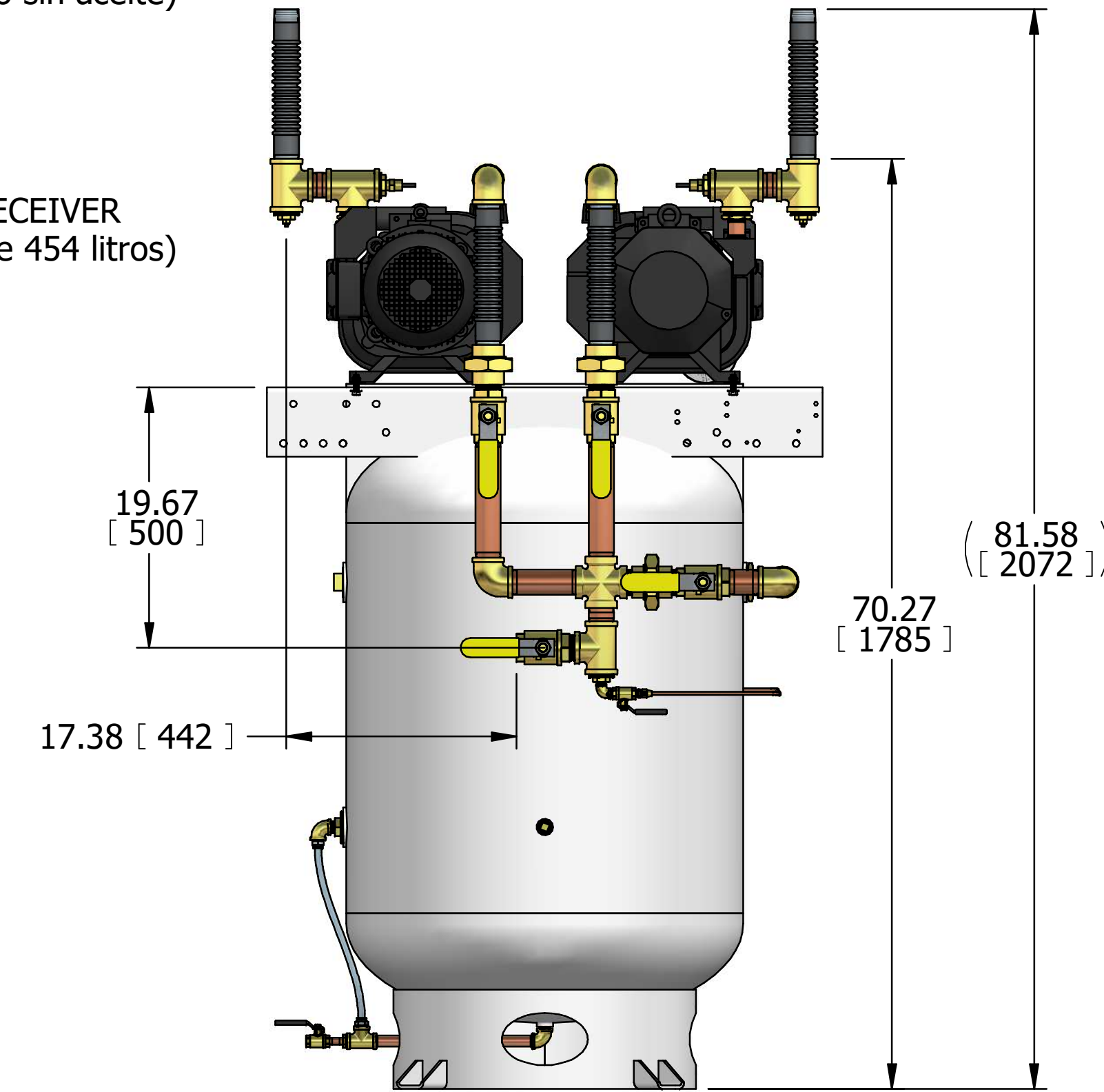
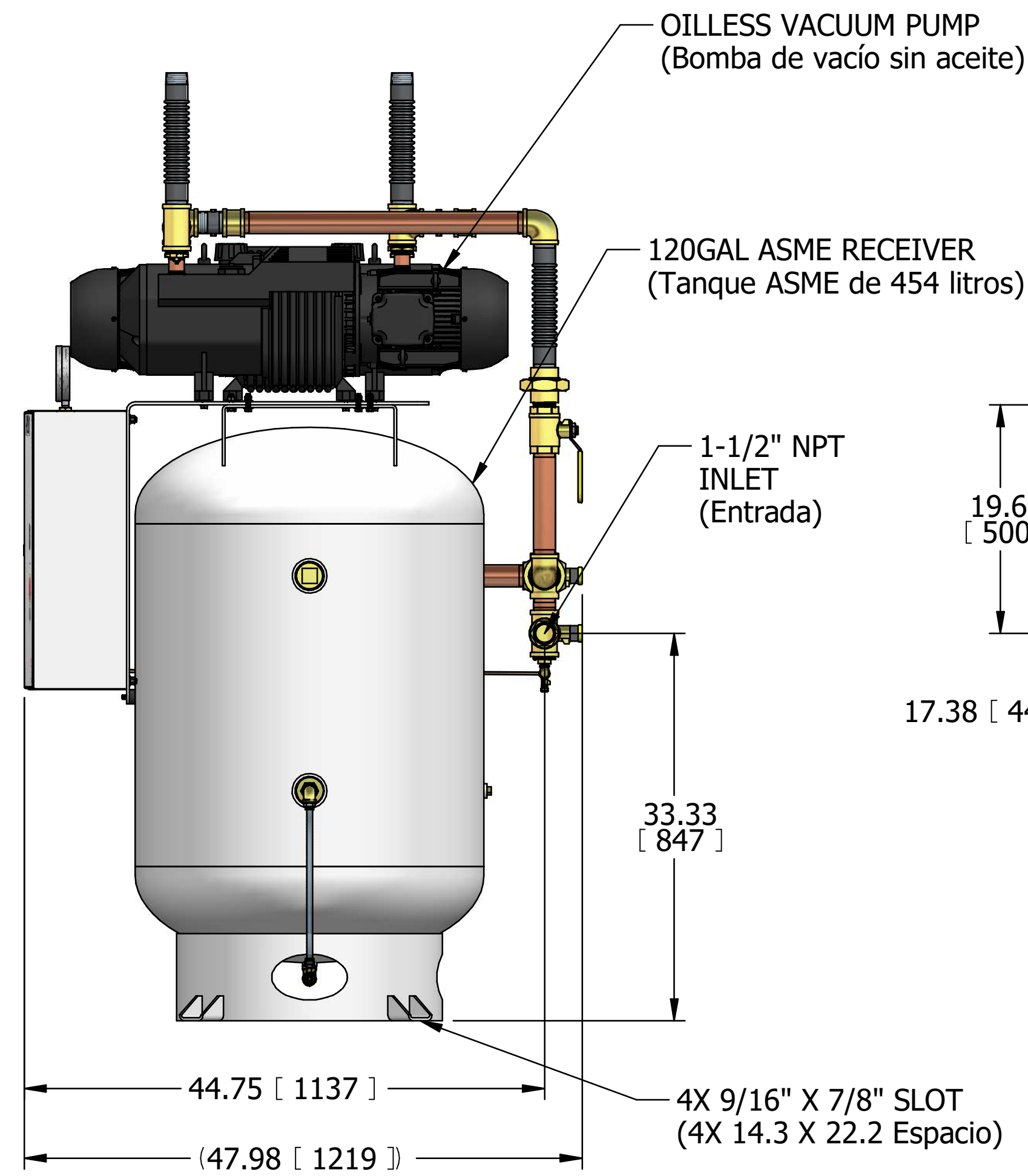
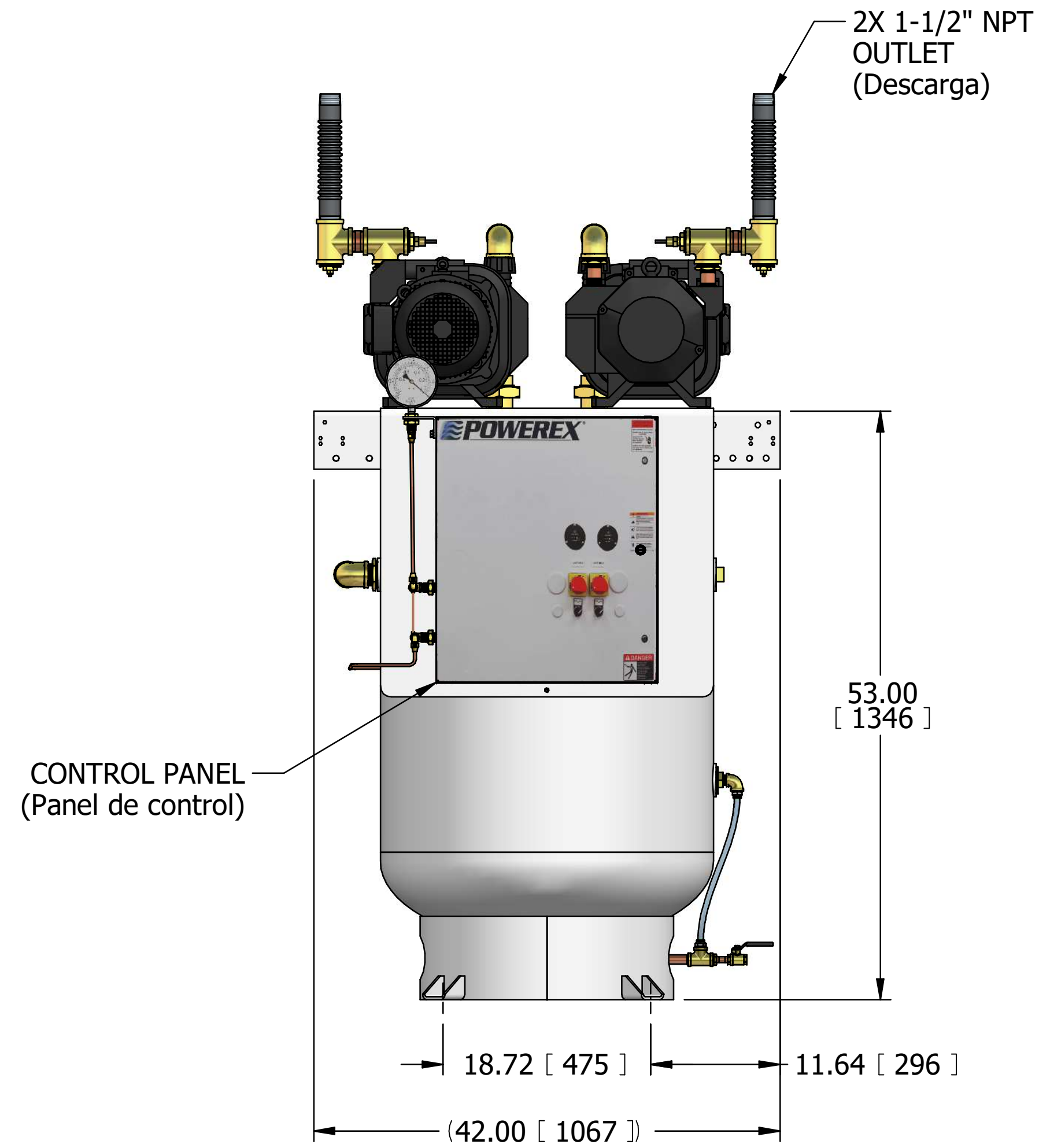

- NOTES:
1. APPROXIMATE WEIGHT: 1138 LBS
 2. A MINIMUM OF 24" CLEARANCE IS RECOMMENDED AROUND THE ENTIRE UNIT. CLEARANCE FOR CONTROL PANEL SHALL BE IN ACCORDANCE WITH OSHA/NEC REQUIREMENTS.
 3. SYSTEM DESIGNED IN COMPLIANCE WITH U.S. NFPA '99, LATEST EDITION.
1. PESO APROXIMADO: 516 kg
 2. RECOMENDAMOS QUE EL ESPACIO LIBRE ALREDEDOR DEL SISTEMA DEBE SER COMO MÍNIMO 24" (600 mm). EL ESPACIO LIBRE PARA EL TABLERO DE CONTROL DEBERÁ ESTAR DE ACUERDO CON LOS REQUERIMIENTOS DE SEGURIDAD DE LA OSHA/NEC.
 3. EL SISTEMA ESTÁ DISEÑADO DE ACUERDO CON LA ÚLTIMA EDICIÓN DE LA NFPA 99.

SYMBOL LEGEND		DRAWINGS TO CONFORM TO CURRENT REVISION OF THE FOLLOWING ANSI STANDARDS:	
		Y14.3 MULTI AND SECTIONAL VIEW DWGS	
		Y14.5 DIMENSIONING AND TOLERANCING	
TOLERANCES, UNLESS OTHERWISE SPECIFIED:		DO NOT SCALE DRAWING FOR DIMENSIONS	
0.XX ± .005	SOLID EDGE DRAWING		
0.XXX ± .005	INCH [mm]	SHEET 1 OF 2	SCALE 1:10
± .1			
CONFIDENTIAL DISCLOSURE This drawing is the property of POWEREX of the SCOTT FEZTER COMPANY and is subject to return on demand. Its contents are confidential and must not be copied or submitted to outside parties for use or examination.		AUTHOR	REVISION DATE
		TATA	3/9/2021
ITEM NO: 719534		APPROVALS ON FILE IN PLM	
MATERIAL: ---		POWEREX™	
		150 PRODUCTION DRIVE, HARRISON OH 45030 (888) 769-7979	
DESCRIPTION	DRAWING NUMBER	REVISION	SIZE
5 HP OILLESS VACUUM DUPLEX 120 GAL	VVOTD0504K1	D	D

VVOTD0504K1

5 HP OILLESS VACUUM DUPLEX 120 GAL

REVISION NOTES		
DESCRIPTION	ECN	PR/NOR
UPDATED DRAWING FOR DUAL DIMENSIONS	PXEC0428	

POWEREX™

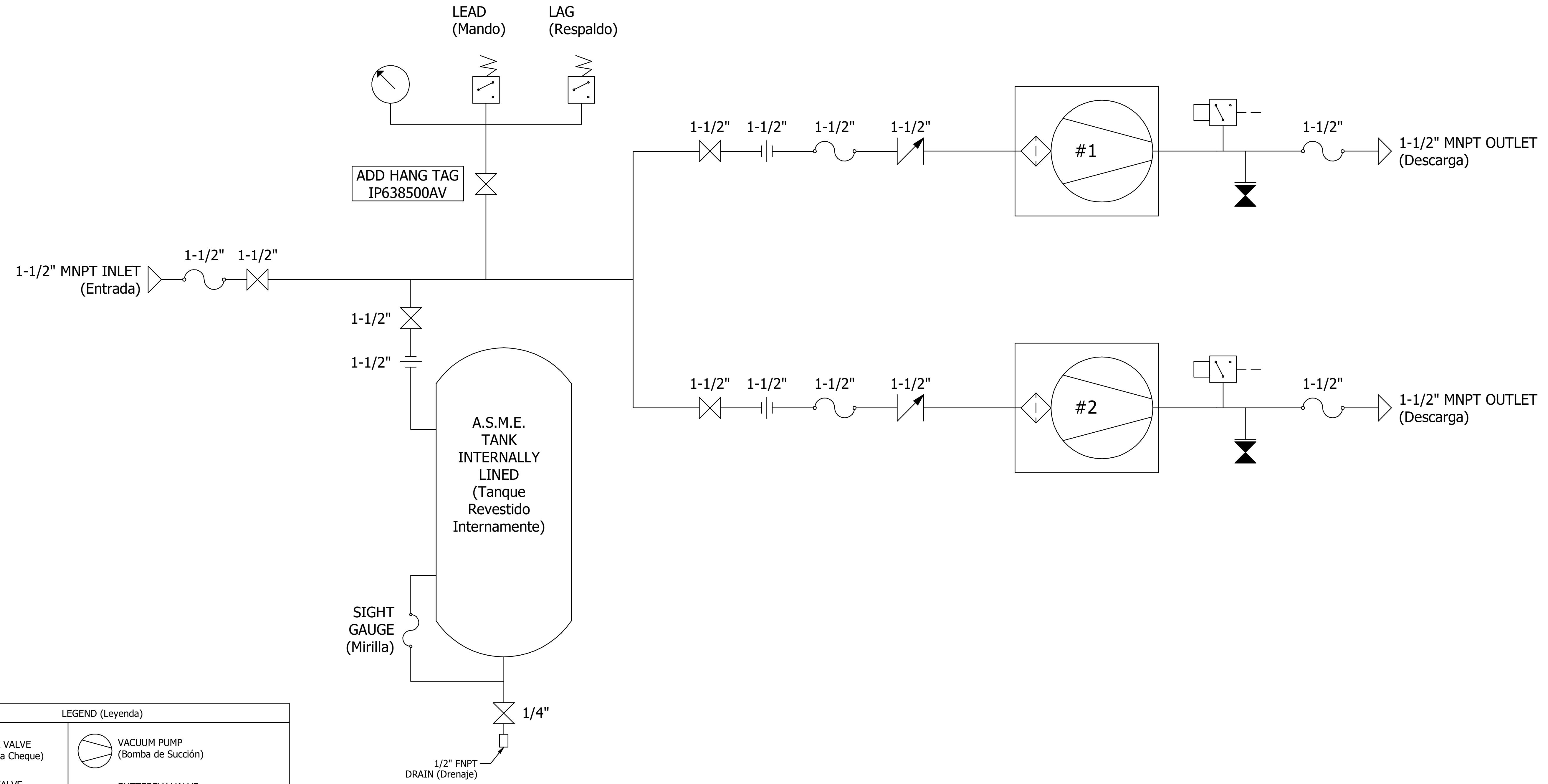

LEGEND (Leyenda)

	CHECK VALVE (Válvula Cheque)		VACUUM PUMP (Bomba de Succión)
	BALL VALVE (Válvula de Bola)		BUTTERFLY VALVE (Válvula de Mariposa)
	INTAKE FILTER (Filtro admisión)		FLEX HOSE (Manguera flexible)
	GAUGE (Manómetro)		TEMPERTURE SWITCH (Interruptor temperatura)
	UNION (Unión)		VACUUM SWITCH/TRANSDUCER (Interruptor/Transductor vacío)
	DRAIN COCK (Grifo de Drenaje)		SOLENOID VALVE (Válvula solenoide)
	AIR LINE (Tubería de Aire)		CONDENSATE LINE (Linea de Condensado)

SYMBOL LEGEND		DRAWINGS TO CONFORM TO CURRENT REVISION OF THE FOLLOWING STANDARDS:	
		Y14.1 MULTI AND SECTIONAL VIEW DWGS Y14.3 DIMENSIONING AND TOLERANCING	
TOLERANCES, UNLESS OTHERWISE SPECIFIED:		SOLID EDGE DRAWING	
0.XX ± .005		DO NOT SCALE DRAWING FOR DIMENSIONS	
0.XXX ± .005		SHEET 2 OF 2	
± .1		SCALE 1:1	
INCH [mm]		APPROVALS ON FILE IN PLM	
CONFIDENTIAL DISCLOSURE		AUTHOR	
This drawing is the property of POWEREX of the SCOTT FEZTER COMPANY and is subject to return on demand. Its contents are confidential and must not be copied or submitted to outside parties for use or examination.		REVISION DATE	
TATA		3/9/2021	
ITEM NO: 719534		POWEREX™	
MATERIAL: ---		150 PRODUCTION DRIVE, HARRISON OH 45030 (888) 769-7979	
DESCRIPTION: 5 HP OILLESS VACUUM DUPLEX 120 GAL		DRAWING NUMBER: VVOTD0504K1	
		REVISION: D	
		SIZE: D	