

Gas Control Panel

Operating & Maintenance Manual

Please read and save these instructions. Read carefully before attempting to assemble, install, operate or maintain the product described. Protect yourself and others by observing all safety information. Failure to comply with instructions could result in personal injury and/or property damage! Retain instructions for future reference.

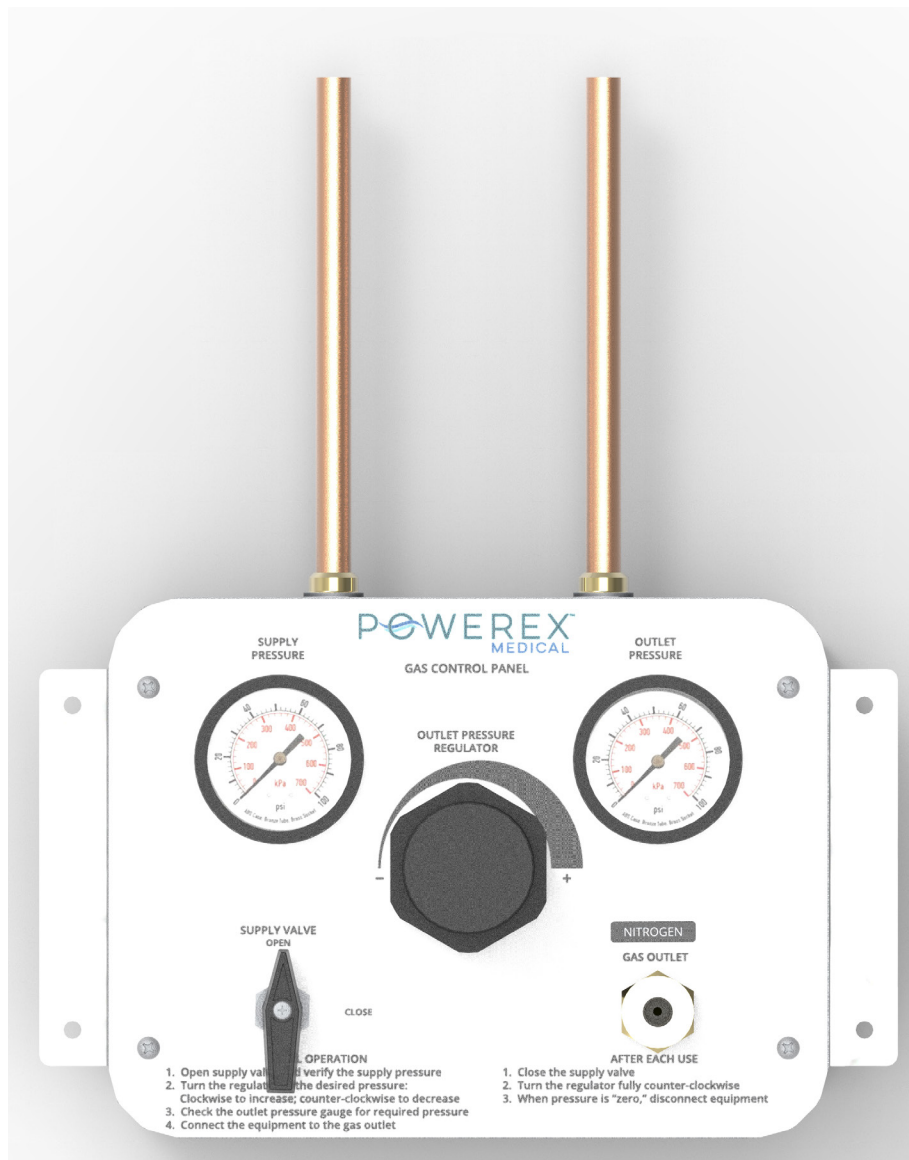

Table of Contents

Responsibilities	4
Installer Responsibilities	4
User Responsibilities	4
Introduction	4
Product Line Overview	4
Applicable Models	4
Installation	5
Parts List	8
Specifications	9
Dimensions	9
Notes	10
Powerex Limited Warranty	11
Warranty and Remedies.	11

Responsibilities

Information contained in this manual pertains to the Powerex Gas Control Panel. The gas control panel will operate as described in this manual when operated and serviced in compliance with the instructions.

Installer Responsibilities

The gas control panel should be handled, installed, and tested per the recommended practice as described within this manual. Should any repair or replacement become necessary, contact Powerex for original equipment or replacement parts.

User Responsibilities

The gas control panel should be tested and examined periodically according to facility codes. Any parts which are found to be damaged, corroded, contaminated, etc. should be replaced.

Introduction

Product Line Overview

The Powerex Gas Control Panel provides adjustable pressure gas for use with pneumatic surgical tools. The gas control panel is cleaned, tested, and prepared for the intended medical gas service. It is constructed in accordance with requirements of the latest edition of CGA. Features and benefits include:

- Designed and manufactured in the USA
- 5 year warranty on parts, 2 year warranty on labor
- Industry-leading flow capacity
- Durable, easy to clean stainless steel front
- Self-relieving 0-250 PSI pressure regulator
- Front Loaded (fast & easy to repair)
- DISS outlet with demand valve
- High quality ball valve
- Painted steel rough in box
- Easy to ready 2" 0-300 PSI gauges
- Compatible with Nitrogen, Instrument Air or Carbon Dioxide.

Applicable Models

- GCP-N20 - Nitrogen
- GCP-INST - Instrument Air
- GCP-CO2 - Carbon Dioxide

Installation

Installation of the Gas Control Panel involves installing the rough-in box and making the necessary piping connections in accordance with NFPA 99.

⚠ WARNING This device should only be installed by qualified personnel. Installation should not be attempted by anyone not having general experience with the installation of devices of this nature.

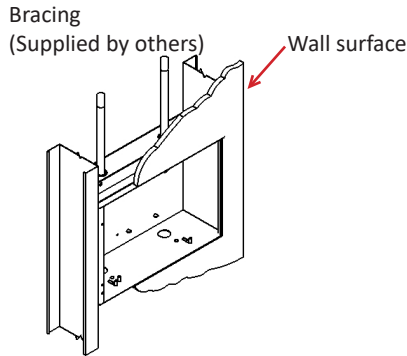

1. Provide rigid mounting that will support the gas control panel back box on the top and bottom. (Rigid mounting materials are not included with the panel). Refer to the building plans to determine location of the panel. Mount back box so it will be flush or just below the finished wall surface. Remove dust cover from back box only when the finished wall surface is complete and you are ready to install the front panel.

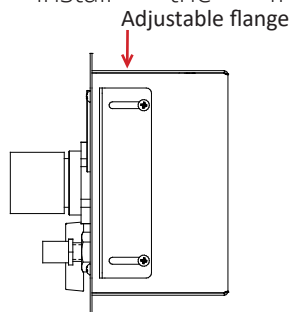

2. Adjustable flanges have been provided on both the right (shown here) and left of the back box. Loosen the screws from the inside of the back box to allow the back box to be adjusted so that it is flush or slightly recessed with the finished wall surface.

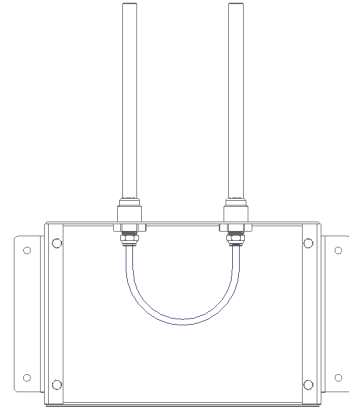

3. Connect the inlet & outlet copper extension tubes to the gas piping system. Make sure drop is for the proper gas service. Using a purge gas to insure cleanliness in the tubes, silver braze the joints. Do not use soft solder! (See NFPA 99 for recommended silver braze alloys). Conduct heat away from the back box. It is recommended that gas piping system tubing be connected from the outlet copper extension tube to the ceiling and capped, even though a continuation of this system may not be intended at this time. Note: The inlet and outlet extension tubes have been pre-piped together at the factory to allow for the required 150 psi standing pressure test.
4. Remove the dust cover when the finished wall surface is complete and you are ready to install the front panel.

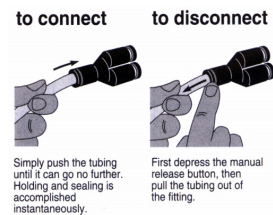

5. The tubing and fittings provided in this panel should be connected and disconnected by hand – without the use of tools. Note: Wash your hands before handling these connections to ensure that oil, grease, dirt etc. do not contaminate the fittings possibly causing leakage and introducing impurities into the medical gas system.

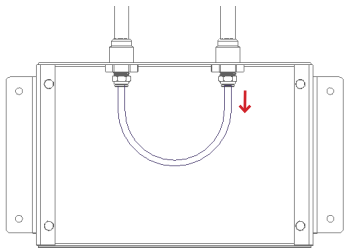

6. Disconnect the gas outlet tube from the fitting inside the back box.

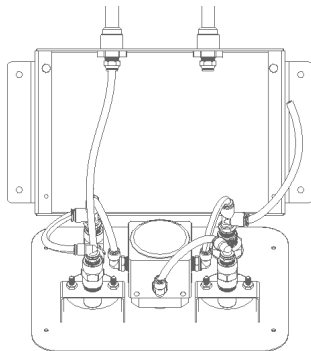

9. Insert the unconnected yellow tube (coming off the run tee on the back of the DISS outlet connection) into the gas outlet fitting in the back box.

10. Again, ensure tubing connections are properly made by tugging on the tubing with slight pressure.

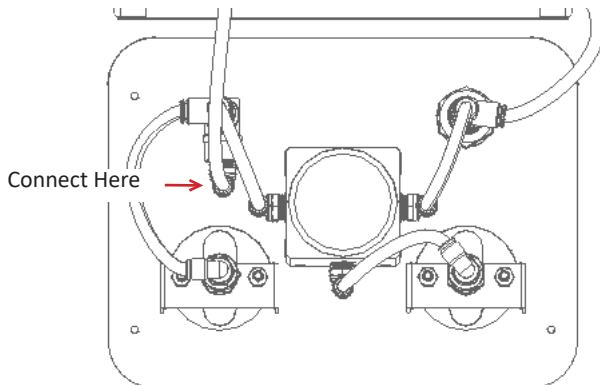

7. Insert the end of the black tube that you just disconnected from the gas outlet fitting into the gas inlet fitting on the back of the valve on the front panel.

8. Ensure tubing connections are properly made by tugging on the tubing with slight pressure.

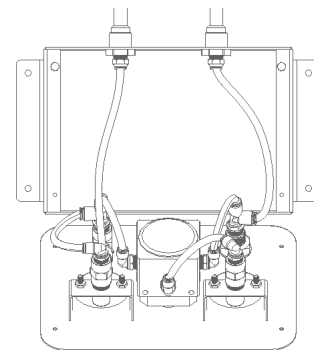
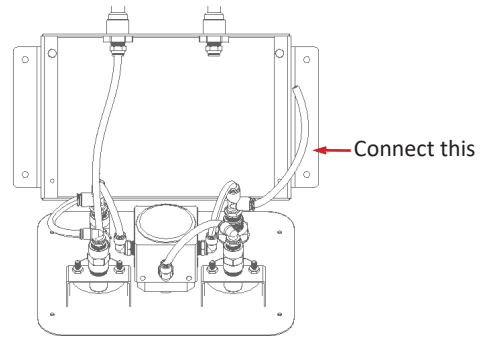

11. Finished tubing connections should look like this.

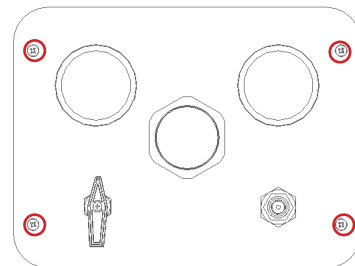

12. Attach the front panel to the back box (using the 4 long screws provided). Be careful not to pinch or damage tubing. The tubing connectors swivel to ease installation. Remove shipping cap.

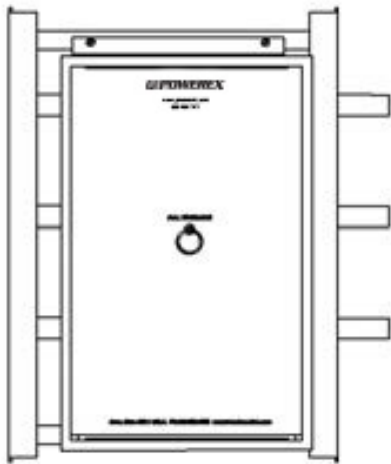

13. The Gas Control panel should now be ready for testing and use. To restore gas service to the panel, locate and open the zone valve providing gas to the gas control panel.

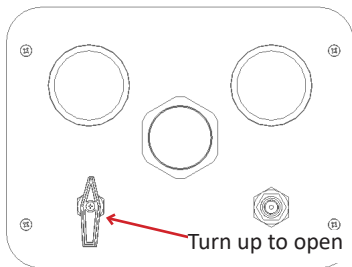

14. Use the Supply Valve on the gas control panel to control gas flow to the panel and equipment connected downstream of the panel.

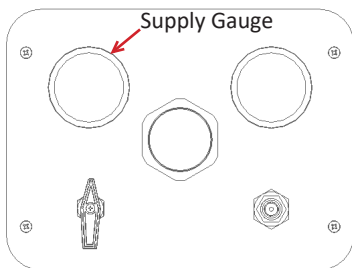

15. A Supply Pressure Gauge (or Inlet Pressure Gauge) is provided to allow monitoring of the pressure being supplied to the gas control panel. The pressure shown on this gauge will match the pressure shown at the zone valve box provided the Supply Valve on the gas control panel is ON or open.

16. The Outlet Pressure Regulator adjusts or regulates the delivery pressure of the gas. Turning the knob clockwise increases the delivery pressure. Turning the knob counterclockwise decreases the delivery pressure. The regulator is self venting which means a small amount of gas will be allowed to escape through the regulator bonnet when the delivery pressure is decreased.

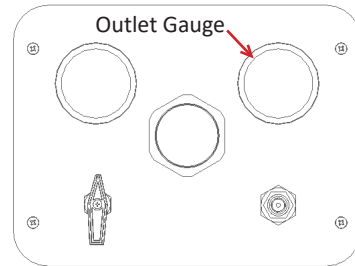

17. The Outlet Pressure Gauge displays the delivery or outlet pressure as controlled by the regulator.

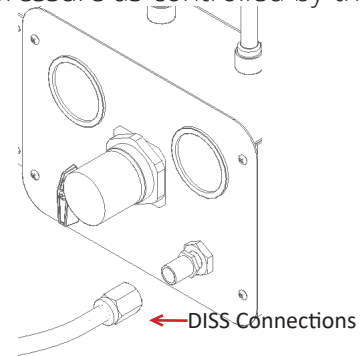

18. The Gas Outlet allows connection of DISS Gas hose assemblies. The outlet connection provides a demand check valve which automatically stops the flow of gas when the hose is disconnected. The Gas Control Panel is now ready for use!

Parts List

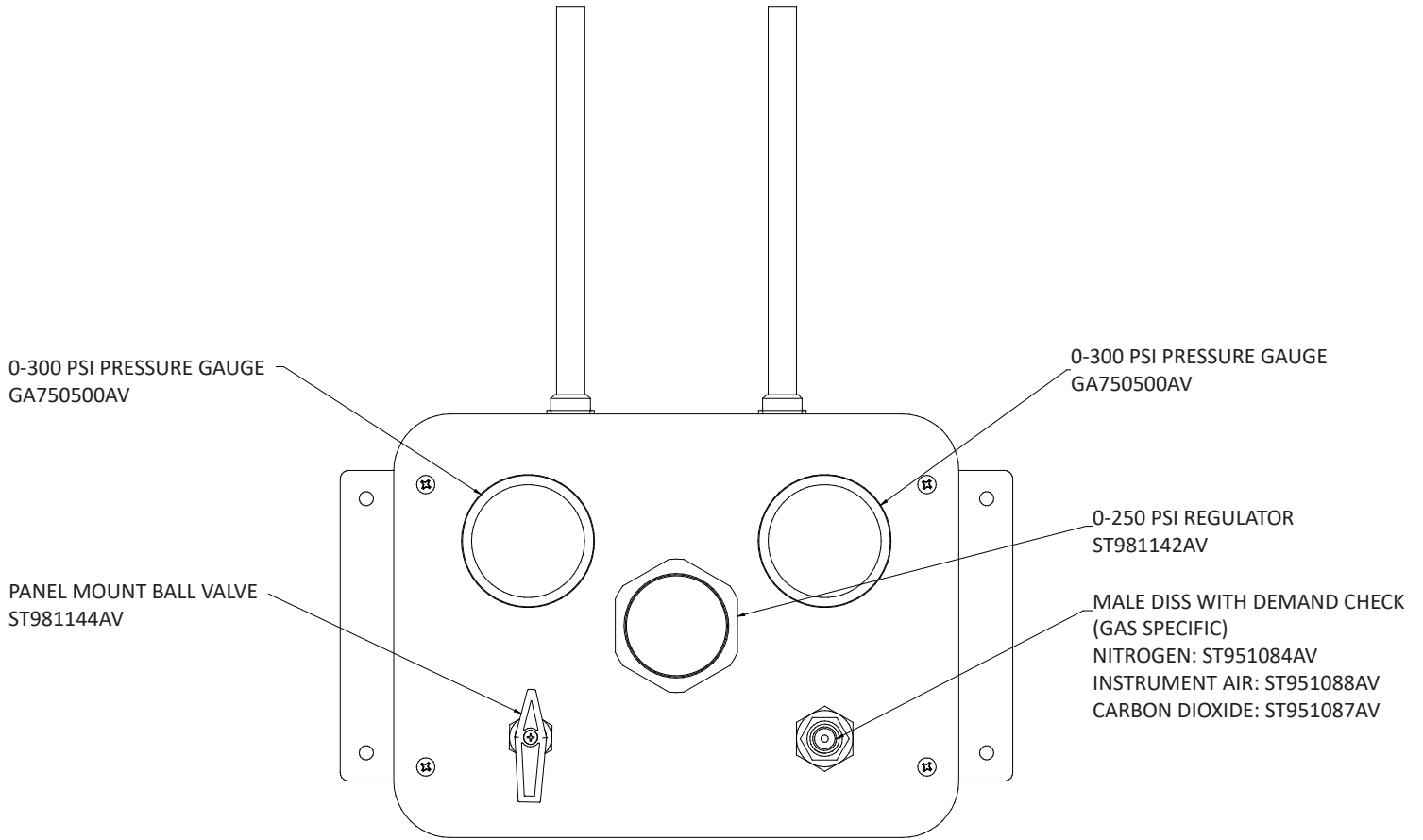

Specifications

Dimensions

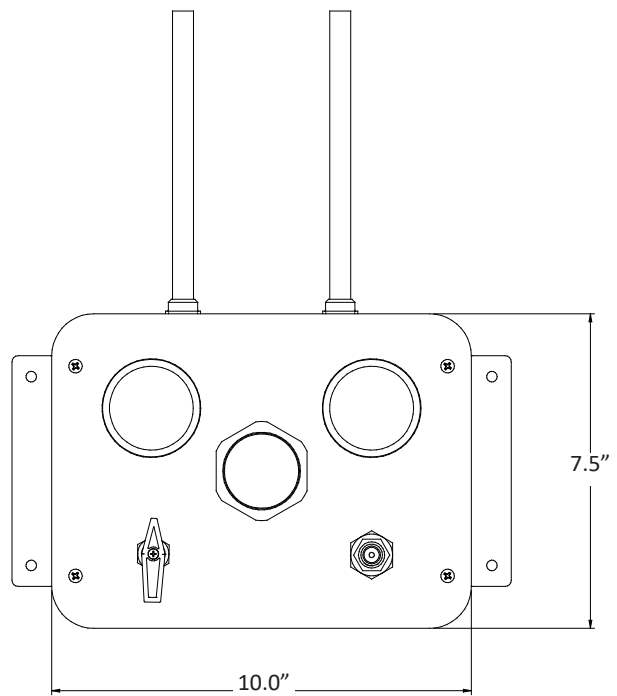
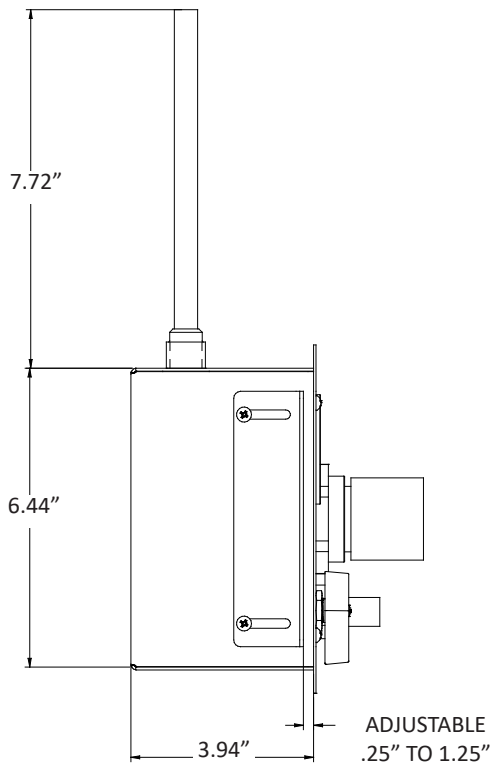
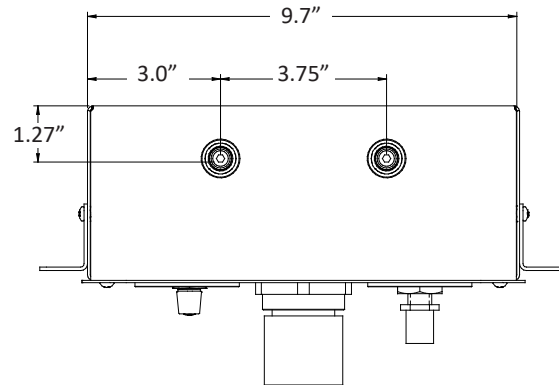

Powerex Limited Warranty

Warranty and Remedies.

(a) Standard Period of Warranty – Parts and Labor. Powerex warrants and represents all Products shall be free from Defects for the first twenty-four (24) months from the date of shipment by Powerex. During such warranty period, Powerex shall be fully liable for all Defects in the Products (the “Product Defects”), i.e., all costs of repair or replacement, which may include “in and out” charges, so long as the Products are located in the United States or Canada, and the Products are reasonably located and accessible by service personnel for removal. “In and out” charges include the costs of removing a Product from buyer’s equipment for repair or replacement.

(b) Additional Period of Warranty – Parts Only (No Labor). In addition to the above, Powerex warrants the products described herein shall be free of Defects for a period of sixty (60) months from the date of shipment by Powerex, with the exception of any components which are recommended to be replaced in less than sixty months in our Installation/Operation manuals. Within said period Powerex will repair or replace any part or component which is proven to be defective in either material or workmanship. This warranty covers parts only. Labor is not included. This warranty is valid only when the product has been properly installed according to Powerex specifications, used in a normal manner and serviced according to factory recommendations. This warranty does not cover failures due to damage which occurs in shipment or failures which result from accidents, misuse, abuse, neglect, mishandling, alteration, misapplication or damage due to acts of nature.

(c) General. Powerex warrants each Powerex branded Pipeline Accessory (collectively “Products”, individually each a “Product”) to be free from defects in material and workmanship (“Defects”) at the date of shipment. EXCEPT AS SET FORTH BELOW, NO OTHER WARRANTY, WHETHER EXPRESS OR IMPLIED, INCLUDING ANY WARRANTY OF MERCHANTABILITY OR FITNESS FOR A PARTICULAR PURPOSE, SHALL EXIST IN CONNECTION WITH THE SALE OR USE OF SUCH PRODUCTS. TO THE EXTENT PERMITTED BY LAW, ANY AND ALL IMPLIED WARRANTIES ARE EXCLUDED. All warranty claims must be made in writing and delivered to Powerex in accordance with the procedures set forth on its website (www.powerexinc.com), or such claim shall be barred. Upon timely receipt of a warranty claim, Powerex shall inspect the Product claimed to have a Defect, and Powerex shall replace any Product which it determines to have had a Defect; provided, however, that Powerex may elect, upon return of the Product, to refund to buyer any part of the purchase price of such Products paid to Powerex. Freight for returning Products to Powerex for inspection or for shipping warranty parts shall be paid by buyer where permitted by applicable law. Powerex is not responsible for any import fees, taxes, duties, licenses or other fees imposed by any governmental authority upon the production, sale, shipment and/or use of Products covered hereunder. The warranties and remedies herein are the sole and exclusive remedy for any breach of warranty or for any other claim based on any Defect, or non-performance of the Products, whether based upon contract, warranty or negligence.

(d) Coverage. The warranty provided herein applies to Powerex pipeline products only.

(e) Exceptions. Notwithstanding anything to the contrary herein, Powerex shall have no warranty obligations with respect to Products:

- (i)** That have not been installed in accordance with Powerex’s written specifications and instructions;
- (ii)** That have not been maintained in accordance with Powerex’s written instructions;
- (iii)** That have been materially modified without the prior written approval of Powerex; or
- (iv)** That experience failures resulting from operation, either intentional or otherwise, in excess of rated capacities or in an otherwise improper manner.

The warranty provided herein shall not apply to: **(i)** any defects arising from corrosion, abrasion, use of insoluble lubricants, or negligent attendance to or faulty operation of the Products; **(ii)** ordinary wear and tear of the Products; or **(iii)** defects arising from abnormal conditions of temperature, dirt or corrosive matter; **(iv)** any OEM component which is shipped by Powerex with the original manufacturer’s warranty, which shall be the sole applicable warranty for such component.

Limitation of Liability. NOTWITHSTANDING ANYTHING TO THE CONTRARY HEREIN, TO THE EXTENT ALLOWABLE

UNDER APPLICABLE LAW, UNDER NO CIRCUMSTANCES SHALL POWEREX BE LIABLE FOR ANY INCIDENTAL, CONSEQUENTIAL, PUNITIVE, SPECULATIVE OR INDIRECT LOSSES OR DAMAGES WHATSOEVER ARISING OUT OF OR IN ANY WAY RELATED TO ANY OF THE PRODUCTS OR GOODS SOLD OR AGREED TO BE SOLD BY POWEREX TO BUYER. TO THE EXTENT ALLOWABLE UNDER APPLICABLE LAW, POWEREX'S LIABILITY IN ALL EVENTS IS LIMITED TO, AND SHALL NOT EXCEED, THE PURCHASE PRICE PAID. In the event of breach of any warranty hereunder, Powerex's sole and exclusive liability shall be at its option either to repair or to replace any defective product, or to accept return, transportation prepaid, of such product and refund the purchase price; in either case provided that written notice of such defect is given to Powerex within twenty-four (24) months from date of shipment to Buyer, that the product is found by Powerex to have been defective at the time of such shipment, that the product has been installed and/or operated in accordance with Powerex's instructions, that no repairs, alterations or replacements have been made by others without Powerex's written approval, and that Buyer notifies Powerex in writing within fifteen (15) days after the defect becomes apparent and promptly furnishes full particulars in connection therewith; and provided further that in no event shall the aggregate liability of Powerex in connection with breach of any warranty or warranties exceed the purchase price paid for the product purchased hereunder. Powerex may, at its option, require the return of any product, transportation and duties prepaid, to establish any claim of defect made by Buyer. Unless otherwise agreed in writing **(a)** Powerex will not accept and shall have no responsibility for products returned without its prior written consent, and **(b)** Powerex will not assume any expense or liability for repairs to products made outside of its plant by third parties. In the event Powerex elects to replace a defective product, costs of installation, labor, service, and all other costs to replace the product shall be the responsibility of Buyer.

Powerex shall not, except as set forth above, be otherwise liable to Buyer or to any person who shall purchase from Buyer, or use, any products supplied hereunder for damages of any kind, including, but not limited to, indirect, special or consequential damages or loss of production or loss of profits resulting from any cause whatsoever, including, but not limited to, any delay, act, error or omission of Powerex. Supplier's repair or replacement of any Product shall not extend the period of any warranty of any Product.

Warranty Disclaimer. Powerex has made a diligent effort to illustrate and describe the Products in its literature, including its Price Book, accurately; however, such illustrations and descriptions are for the sole purpose of identification, and do not express or imply a warranty that the Products are merchantable, or fit for a particular purpose, or that the Products will necessarily conform to the illustrations or descriptions.

Product Suitability. Many jurisdictions have codes and regulations governing sales, construction, installation, and/or use of Products for certain purposes, which may vary from those in neighboring areas. While Powerex attempts to assure that its Products comply with such codes, it cannot guarantee compliance, and cannot be responsible for how the product is installed or used. Before purchase and use of a Product, please review the Product applications, and national and local codes and regulations, and be sure that the Product, installation, and use will comply with them.

Claims. Any non-warranty claims pertaining to the Products must be filed with Powerex within (6) months of the invoice date, or they will not be honored. Prices, discounts, and terms are subject to change without notice or as stipulated in specific Product quotations. Powerex shall not be liable for any delay or failure arising out of acts of the public enemy, fire, flood, or any disaster, labor trouble, riot or disorder, delay in the supply of materials or any other cause, whether similar or dissimilar, beyond the control of Company. All shipments are carefully inspected and counted before leaving the factory. Please inspect carefully any receipt of Products noting any discrepancy or damage on the carrier's freight bill at the time of delivery. Discrepancies or damage which obviously occurred in transit are the carrier's responsibility and related claims should be made promptly directly to the carrier. Returned Products will not be accepted without prior written authorization by Powerex and deductions from invoices for shortage or damage claims will not be allowed. **UNLESS OTHERWISE AGREED TO IN WRITING, THE TERMS AND CONDITIONS CONTAINED IN THIS LIMITED WARRANTY WILL CONTROL IN ANY TRANSACTION WITH POWEREX.** Any different or conflicting terms as may appear on any order form now or later submitted by the buyer will not control. All orders are subject to acceptance by Powerex.