

POWEREX™

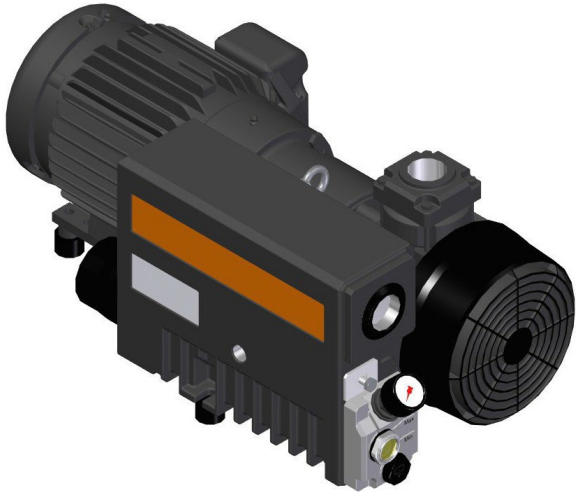

Industrial Vacuum Systems

Lubricated Rotary Vane Pump



Our industrial vacuum tank mount systems feature a lubricated rotary vane pump, one of the simplest and most reliable pump types available. The use of oil in the pump produces higher efficiencies, lower operating temperatures, and lower sound levels. These pumps are also the most suitable for high ambient temperatures, which makes them ideal for manufacturing or process applications where environmental temperatures tend to be higher. The lubricated rotary vane pumps have the lowest initial cost and high ultimate vacuum levels. By tank mounting the pumps on an ASME air receiver and adding a UL listed NEMA 1 control panel, Powerex has designed systems that are perfect for applications like material handling, packing, pharmaceutical, food processing, printing, environmental, gas generation, petrochemical, laboratories, instrumentation, chemical processing, and manufacturing.

Powerex is a proud manufacturer of ISO8573-1:2010 “Class Zero” Oil-free compressed air and vacuum systems. By utilizing our oil-less scroll and oil-free rotary tooth technology, Powerex becomes your premiere source for critical air applications such as food and beverage, laboratory, and critical-process industrial applications. We are an ISO 9001:2008 manufacturing facility that is able to provide complete air systems including tanks, UL508A control panels, and dryers.



Systems Specifications

IBVS – Simplex Systems

Model	SCFM @ 19" Hg	SCFM @ 0" Hg	HP	Tank Size (gal)
IBVS015	7	18	1.5	30 V/60 V
IBVS020	11	28	2	60 V
IBVS030	17	45	3	80 V
IBVS040	25	71	5	80 H
IBVS050	37	103	5	80 H
IBVS075	52	141	7.5	120 H
IBVS100	77	212	10	120 H/200 H
IBVS1506	111	305	15	240 H
IBVS2006	137	375	20	240 H
IBVS2506	168	455	25	240 H

IBVD – Duplex Systems

Model	SCFM @ 19" Hg	SCFM @ 0" Hg	Total HP	Tank Size (gal)
IBVD015	14	36	3	80H
IBVD020	22	56	4	80 H
IBVD030	34	90	6	80 H/120 H
IBVD040	50	142	10	120 H
IBVD050	74	206	10	120 H/200 H
IBVD075	104	282	15	200 H
IBVD100	154	424	20	200 H/240 H
IBVD1506	222	610	30	240 V
IBVD2006	274	750	40	240 V
IBVD2506	336	910	50	240 V

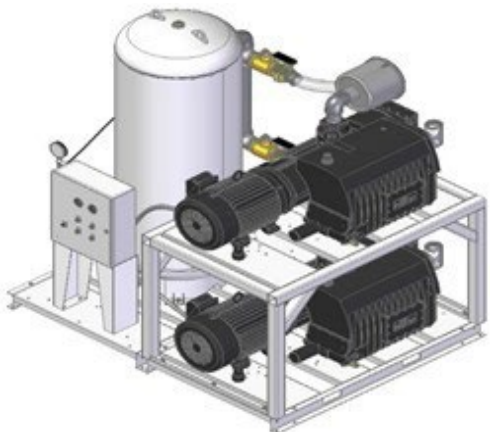
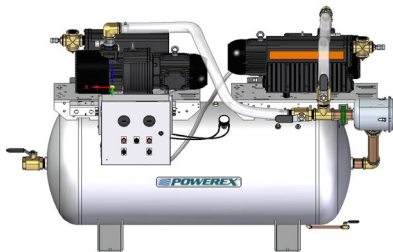

Standard Features

- UL508A control panel
- High temperature alarm
- Condensate Drain
- ASME receiver

Optional Add-ons

- NEMA 4 control panel
- Auto purge with NEMA 4 panel
- Lined tank
- Exhaust flex hose (accessory)
- Vacuum regulator
- Inlet air filters

Key Benefits

- 29.3" Hg end vacuum
- Integrated coalescing filter
- Low annual maintenance cost
- Easy installation
- Low operating temperatures

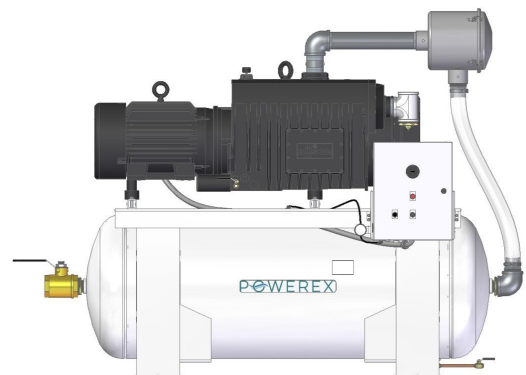

Systems Specifications

IBVT - Triplex Systems				
Model	SCFM @ 19" Hg	SCFM @ 0" Hg	Total HP	Tank Size (gal)
IBVT0505	78	309	15	200 V
IBVT1006	195	636	30	240 V
IBVT1506	333	915	45	240 V
IBVT2006	411	1125	60	240 V
IBVT2506	504	1365	75	240 V

IBVQ- Quadplex Systems				
Model	SCFM @ 19" Hg	SCFM @ 0" Hg	Total HP	Tank Size (gal)
IBVQ0506	104	412	20	240 V
IBVQ0756	208	564	30	240 V
IBVQ1006	260	848	40	240 V
IBVQ1506	444	1220	60	240 V
IBVQ2006	548	1500	80	240 V
IBVQ2506	672	1820	100	240 V

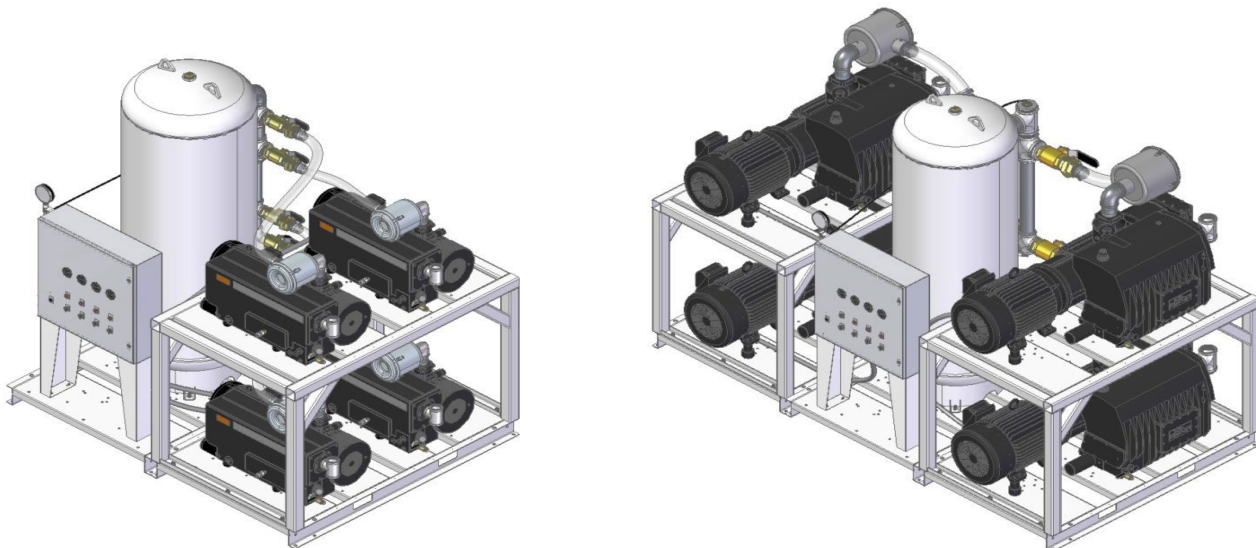

Base-Mount Systems Specifications

Simplex				
Base Model	System HP	SCFM @ 19" Hg	SCFM 0" Hg	BUSCH Vane Pump
IBVS015	1.5	7	18	RA0025
IBVS020	2	11	28	RA0040
IBVS030	3	17	45	RA0063
IBVS040	5	25	71	RA0100
IBVS050	5	37	103	RA0155A
IBVS075	7.5	52	141	RA0205
IBVS090	10	65	177	RA0255
IBVS100	10	77	212	RA0305
IBVS150	15	111	305	RC0400
IBVS200	20	137	375	RC0502
IBVS250	25	168	455	RC0630

Duplex				
Base Model	System HP	SCFM @ 19" Hg	SCFM 0" Hg	BUSCH Vane Pump
IBVD015	3	50	142	RA0025
IBVD020	4	74	206	RA0040
IBVD030	6	104	282	RA0063
IBVD040	10	130	354	RA0100
IBVD050	10	154	424	RA0155A
IBVD075	15	222	610	RA0205
IBVD090	20	130	354	RA0255
IBVD100	20	336	910	RA0305
IBVD150	30	0	0	RC0400
IBVD200	40	0	0	RC0502
IBVD250	50	336	910	RC0630

The industrial vacuum Base-Mount systems are tank-less systems. Depending on the application systems can connect to an existing receiver or controls.

Standard Features

- UL508A control panel
- Vacuum Gauge
- Inlet air Filter
- High temperature alarm
- Condensate Drain

Optional Add-ons

- NEMA 4 control panel

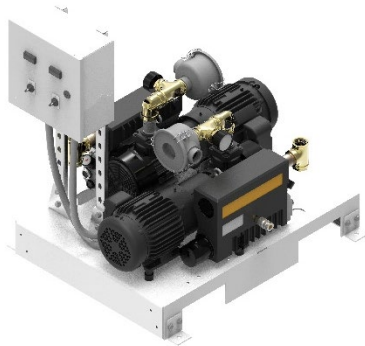

IBVD015

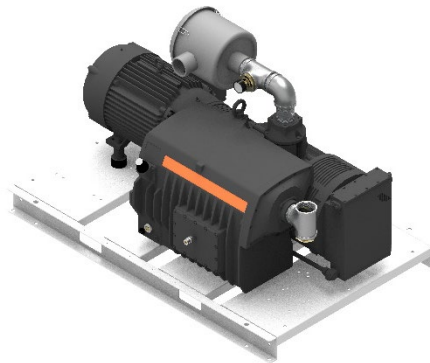

IBVS250

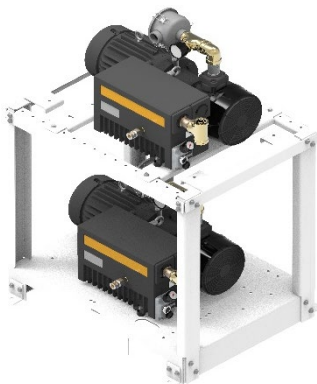

IBVD030

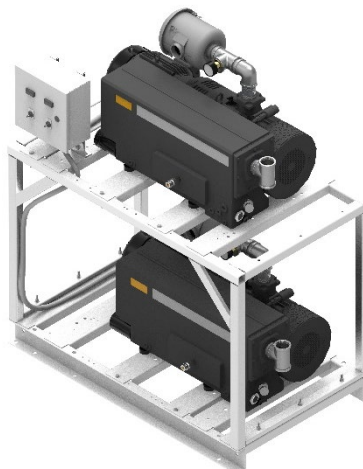

IBVD100

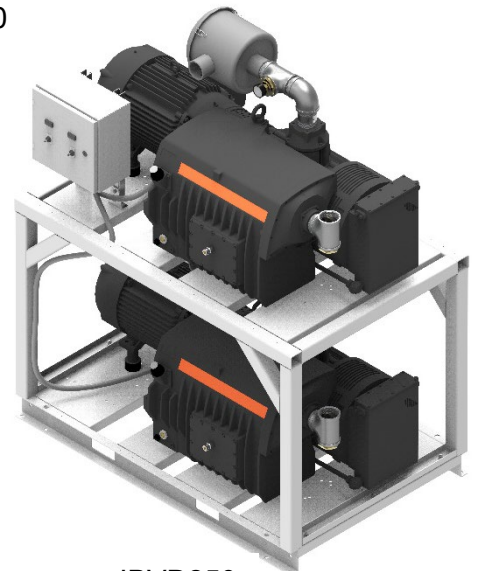

IBVD250



POWEREX™

100 Mundy Memorial Drive • Mount Juliet, TN 37122 • USA
T 1.888.769.7979 • F 513.367.3125 • www.powerexinc.com
SL5995-BR-00 • 16 October 2020



**Designed &
Manufactured
in the USA**

with U.S. and Imported Components